



ISOMAG

The friendly magmeter

DATA SHEET

MS3810

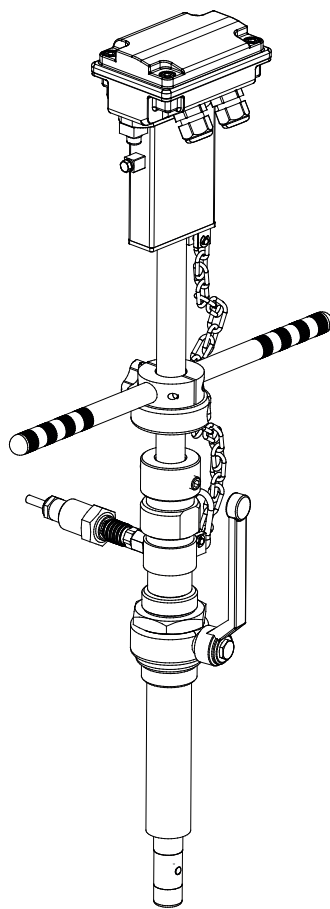

CE



Certified to
NSF/ANSI/CAN 61



ISOIL 
INDUSTRIA



INDEX

TECHNICAL DATA	2
OVERALL DIMENSIONS	3
MS3810 LAYOUT	4
SENSOR VERSIONS / JUNCTIONS BOX	5
SEPARATE VERSION	6
INSTALLATION RECOMMENDATIONS	7
SENSOR GROUNDING	8
MS3810 PRESSURE SENSOR INSTALLATION	8
MAXIMUM ALLOWED SPEED	9
ACCURACY TABLE	10
ISOFLOW PROFILER	11
HOW TO ORDER	13



The manufacturer guarantees only English text available on our web site www.isoli.com

TECHNICAL DATA

OVERALL FEATURES	
Size for pipe line Ø	<input type="checkbox"/> Size 0 max insertion depth 150 mm <input type="checkbox"/> Size 1 max insertion depth 300 mm <input type="checkbox"/> Size 2 max insertion depth 500 mm <input type="checkbox"/> Size 3 max insertion depth 700 mm <input type="checkbox"/> Size 4 max insertion depth 1000 mm <input type="checkbox"/> Size 5 max insertion depth 2000 mm <input type="checkbox"/> Size 9 max insertion depth 80 mm
Minimum conductivity	<input type="checkbox"/> 5 µS/cm (20 µS/cm for MV145/MV255)
Minimum pipe diameter	<input type="checkbox"/> 80 mm
Humidity Range	<input type="checkbox"/> 0÷100% (IP 68)
Accuracy	<input type="checkbox"/> See table at page 10
CE Certification	<input type="checkbox"/> Yes
STANDARD FEATURES	
Body material	<input type="checkbox"/> Stainless steel AISI 316
Nominal pressure	<input type="checkbox"/> 2500 kPa
Process connection	<input type="checkbox"/> 1" Threaded
Version – protection rating	<input type="checkbox"/> According To Converter Version
Connection material	<input type="checkbox"/> Stainless steel AISI 304
Head material	<input type="checkbox"/> PEEK
Gasket material	<input type="checkbox"/> FPM (O-ring)
Liquid temperature	<input type="checkbox"/> 0 °C to 100 °C
Electrodes material	<input type="checkbox"/> Hastelloy C276 / AISI 316L
OPTIONAL FEATURES (CHECK FOR MORE DETAILS 'HOW TO ORDER' ON LAST PAGE)	
Size for pipe line Ø	<input type="checkbox"/> Other on request
Body material	<input type="checkbox"/> Others on request
Process connection	<input type="checkbox"/> Others on request
Electrodes material	<input type="checkbox"/> Others on request
Version – protection rating	<input type="checkbox"/> Separate version (max 20m) – IP 68 <input type="checkbox"/> Separate version (max 500 m), with preamplifier – IP 67 (OPT. IP 68)
Accessories	<input type="checkbox"/> Pressure sensor

OVERALL DIMENSIONS

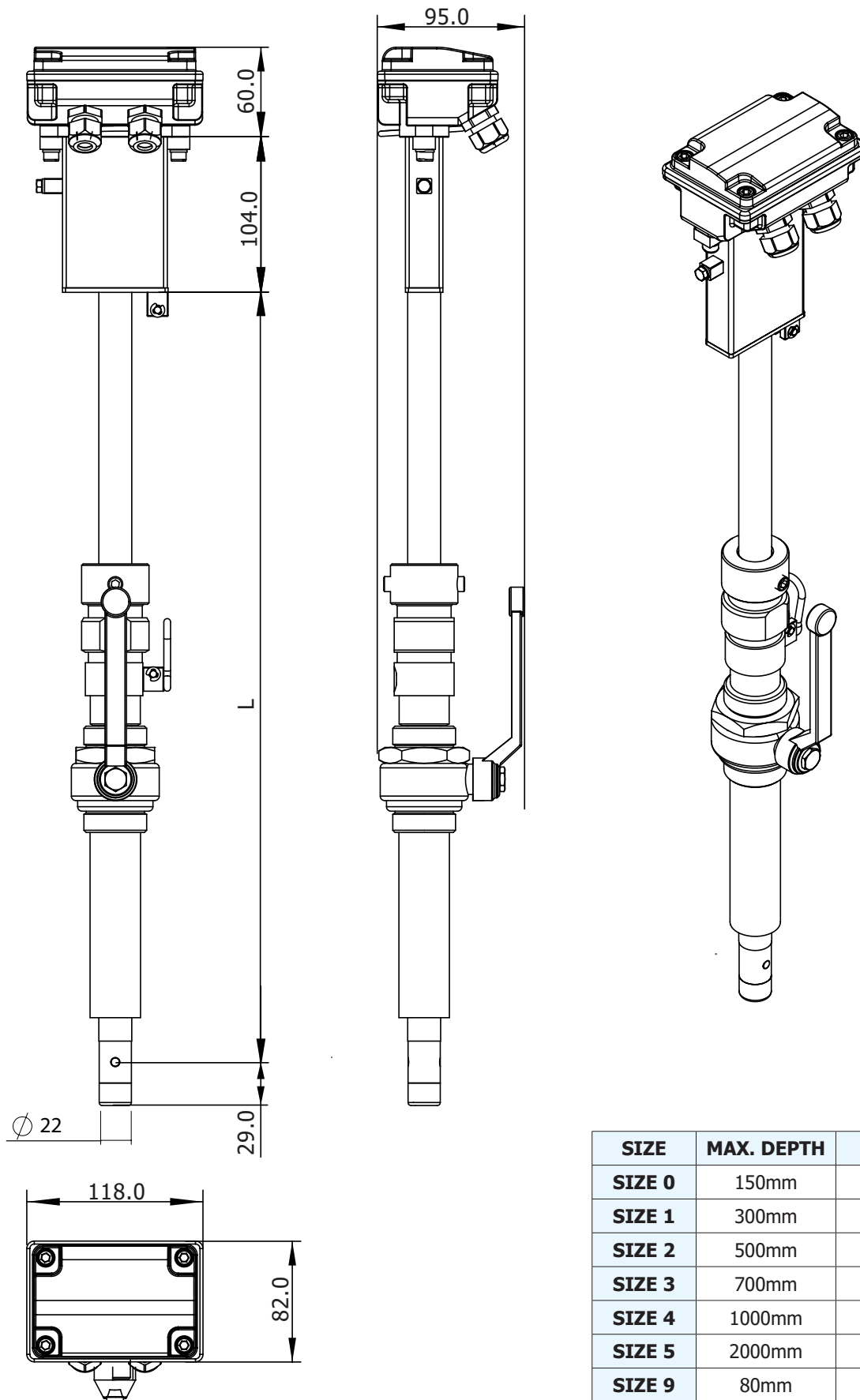

The manufacturer guarantees only English text available on our web site www.isoli.com

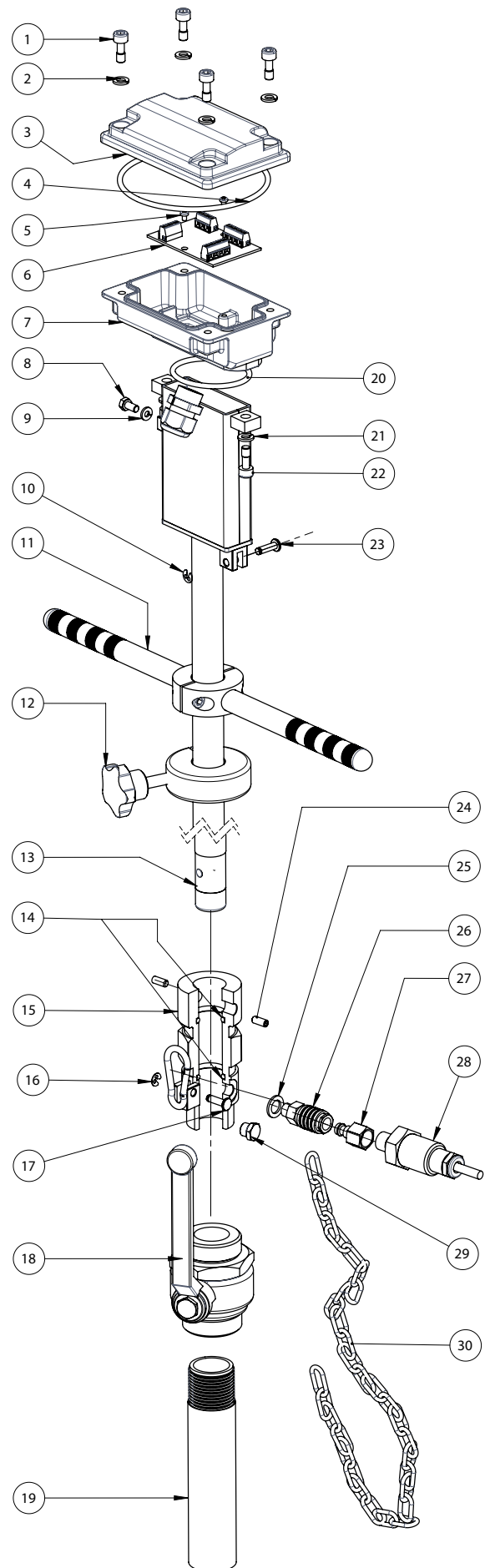

MS3810 LAYOUT

POS.	DESCRIPTION
1	SCREW 6X16
2	GROWER Ø6
3	JUNCTIONS BOX COVER
4	O-RING 4400
5	SCREW M4x6
6	PCB FOR SEPARATE VERSION (NORMAL OR PREAMPLIFIER)
7	JUNCTIONS BOX MAIN HOUSING
8	SCREW M5x10
9	GROWER Ø5
10	SEGGER 4X9 (RING 4 7434-75)
11	HANDLE PUSH
12	FIXING KNOB
13	SENSOR MS3810
14	O-RING 4087
15	CYLINDER LINER
16	SEGGER 4X9 (RING 4 7434-75)
17	PIN FOR INSERT
18	BALL VALVE
19	WELDED PIPE 1"
20	O-RING 155
21	GROWER Ø6
22	SCREW 6X16 WORKED
23	PIN FOR INSERT
24	GRUB SCREW M10X12
25	WASHER
26	QUICK FEMALE
27	QUICK MALE
28	PRESSURE SENSOR
29	CUP PRESSURE HOLE
30	SAFETY CHAIN

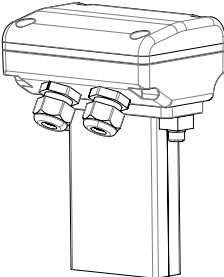
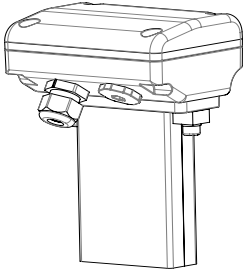
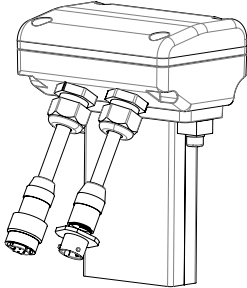
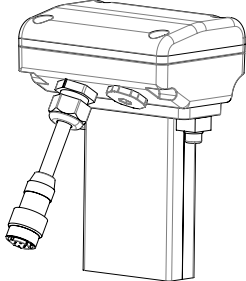
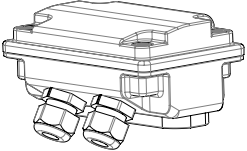

The manufacturer guarantees only English text available on our web site www.isoil.com

SENSOR VERSIONS / JUNCTIONS BOX

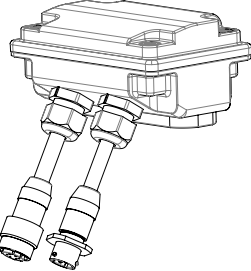
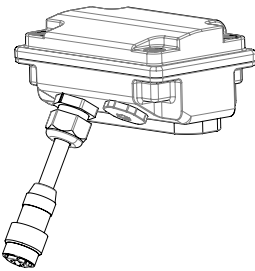
	1	2	3	4
A PAINTED ALUMINIUM				
B AISI 304				

PRICE LIST OPTIONS	JUNCTION BOX TYPE (surface finish)
A	Without junction box, converter connected on the connections box
B	A-1 A-2 only for MV110
G	A-4
F	A-3
N	A-2 with preamplifier
Q	A-4 with preamplifier
U	B-1 (raw) B-2 only for MV110 (raw)
S	B-4 (raw)
T	B-3 (raw)
P	B-2 with preamplifier (raw)
R	B-4 with preamplifier (raw)
K	B-1 (polished) B-2 only for MV110 (polished)
Y	B-4 (polished)
W	B-3 (polished)
V	B-2 with preamplifier (polished)
J	B-4 with preamplifier (polished)

SEPARATE VERSION

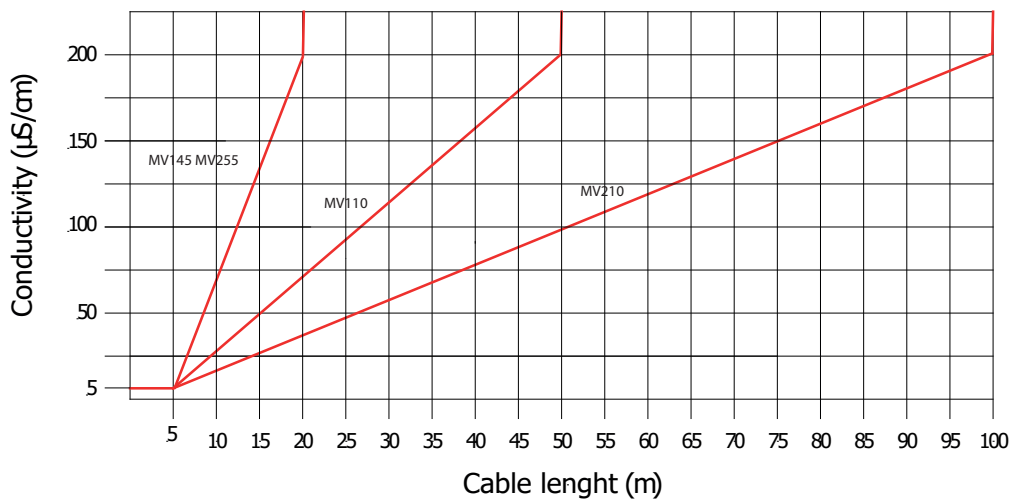
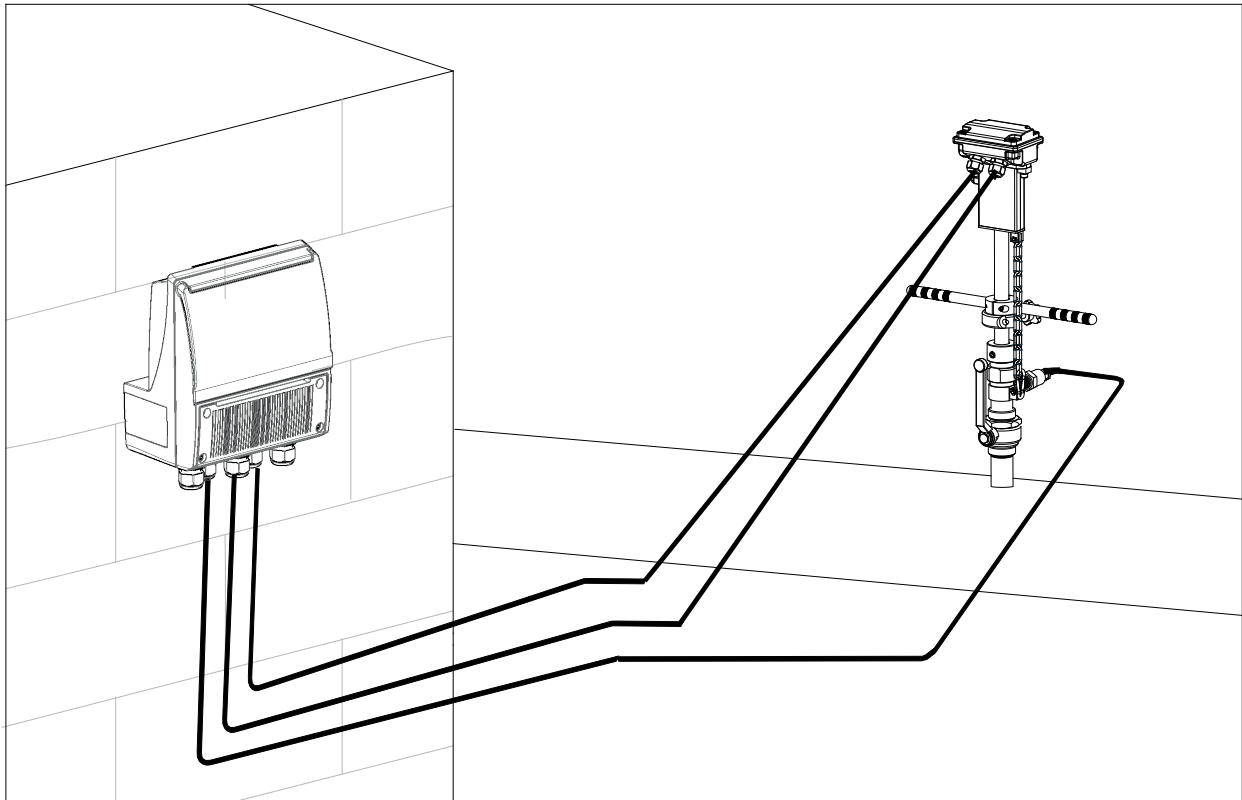

Notes:

- It is recommended to install the connection cables away from, or protect against sources of electromagnetic noise.
- The minimum conductivity of the liquid medium to ensure correct functionality of the empty pipe detection is 20 µS/cm

The manufacturer guarantees only English text available on our web site www.isoil.com

INSTALLATION RECOMMENDATIONS

In vertical installations an ascending flow is preferable.
For vertical installations with descending flow direction contact the manufacturer

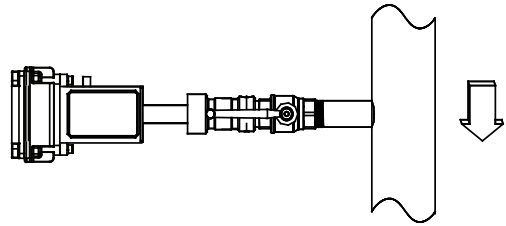
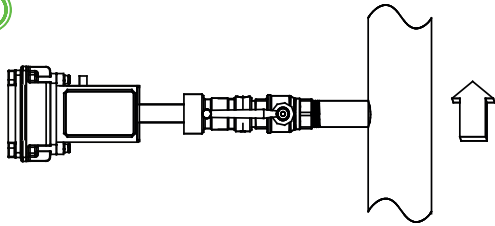

Avoid a partially empty pipe, during operation the pipe must be either completely full of liquid or completely empty

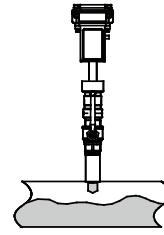
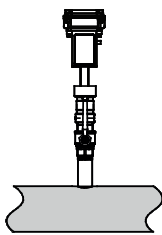

Install the sensor away from bends and hydraulic accessories

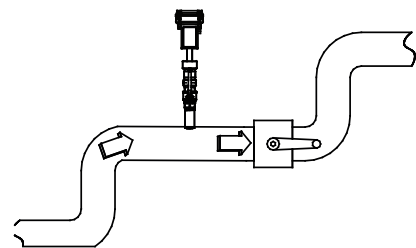
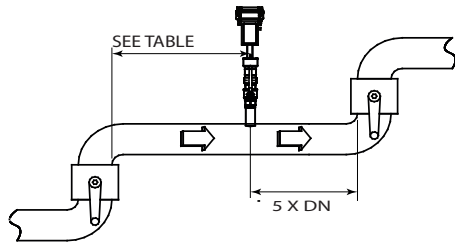

Tighten the two fixing screws before opening the ball valve

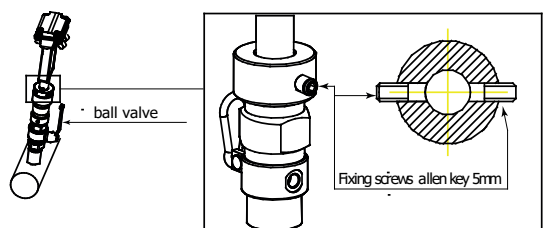
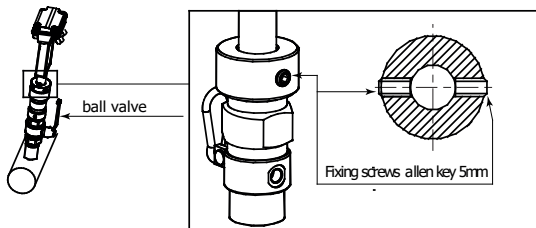

SENSOR GROUNDING

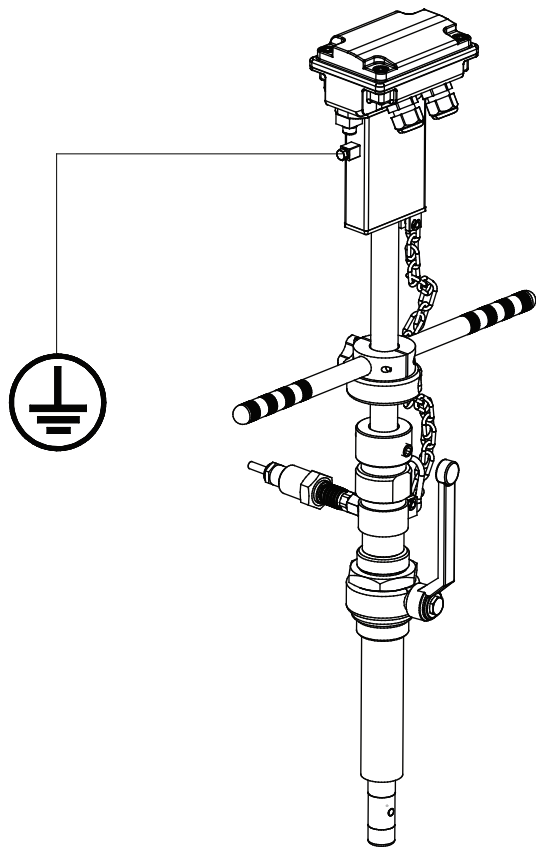

MS3810 PRESSURE SENSOR INSTALLATION

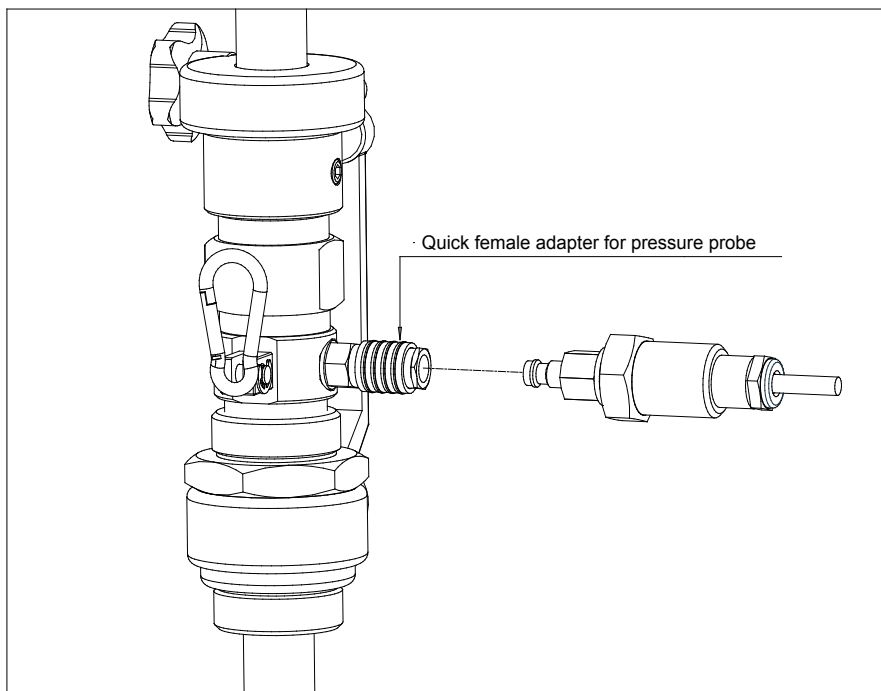

The manufacturer guarantees only English text available on our web site www.isoil.com

MAXIMUM ALLOWED SPEED

WARNING! The insertion and extraction operations of the insertion instruments are operations that can be dangerous when working with a pressure tube.

The pressure inside the tube apply a significant force on the probe that can be ejected violently, creating dangerous situations for the operators. However, the protection chain provided by the instrument does not allow it to completely exaction from the cylinder linear.

It is recommended to perform the insertion or extraction operations of the insertion instrument in safe conditions, if possible with reduced safe working pressure.

The extraction operations can be dangerous as well as for the risk connected to the ejection forces of the probe, also due to the possible leakage of liquid from the piping caused by incorrect operation or defect in the shut-off valve. The following are the indicative values of expulsion force at different pressure values:

Internal Pressure probe [bar]	Expulsion force [kg]
6	30
10	50
16	80
25	125

MAXIMUM ALLOWED SPEED

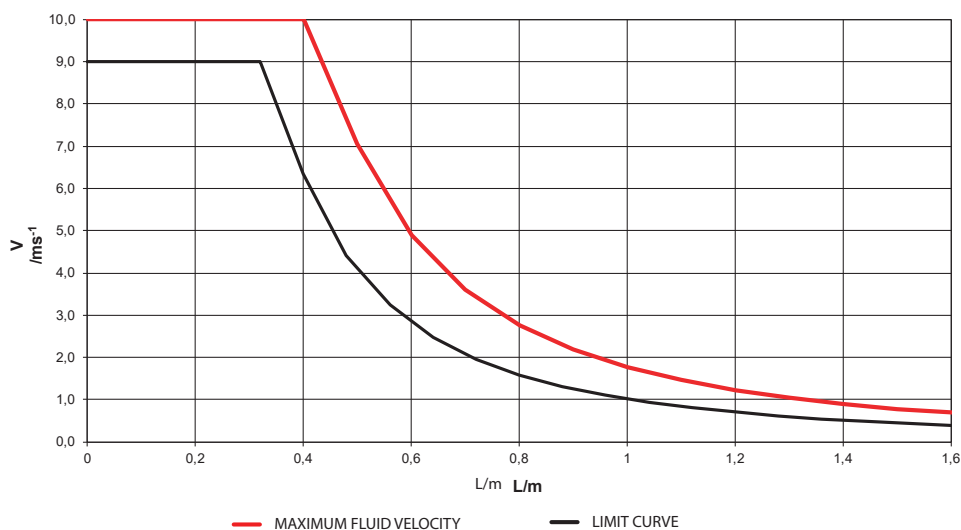

Insertion depth	Maximum fluid velocity
L	V
m	ms-1
0.10	10.0
0.20	10.0
0.30	10.0
0.40	10.0
0.50	7.06
0.60	4.91
0.70	3.60
0.80	2.76
0.90	2.18
1.00	1.77
1.10	1.46
1.20	1.23
1.30	1.04
1.40	0.90
1.50	0.78
1.60	0.69

ACCURACY TABLE

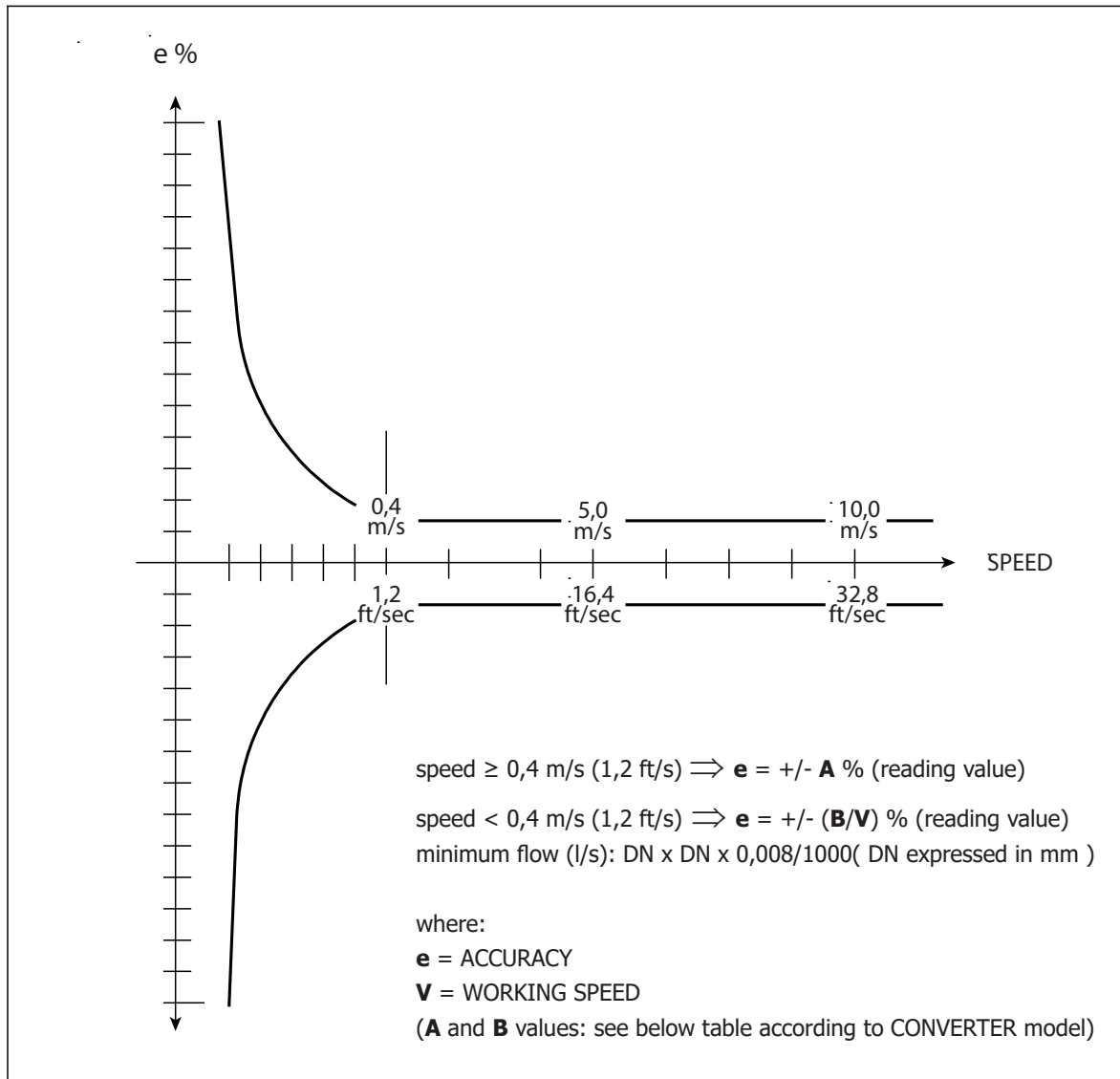

A	B (speed m/s)	B (speed ft/s)
2	0,8	0,24

Reference conditions:

- Constant flow rate during the test
- Pressure: > 30 kPa
- Flow condition : fully developed flow profile
- Zero stability +/- 0,005 %
- ID accuracy: mean value better than 1%, IDmin/IDmax>0,98

ISOFLOW PROFILER

Flow Profiler is an application designated to calculate the value of the correction coefficients K_i and K_p when the flow profile is not fully developed. This is achieved by measuring the flow velocity at different insertion depths along pipe diameter.

Main page

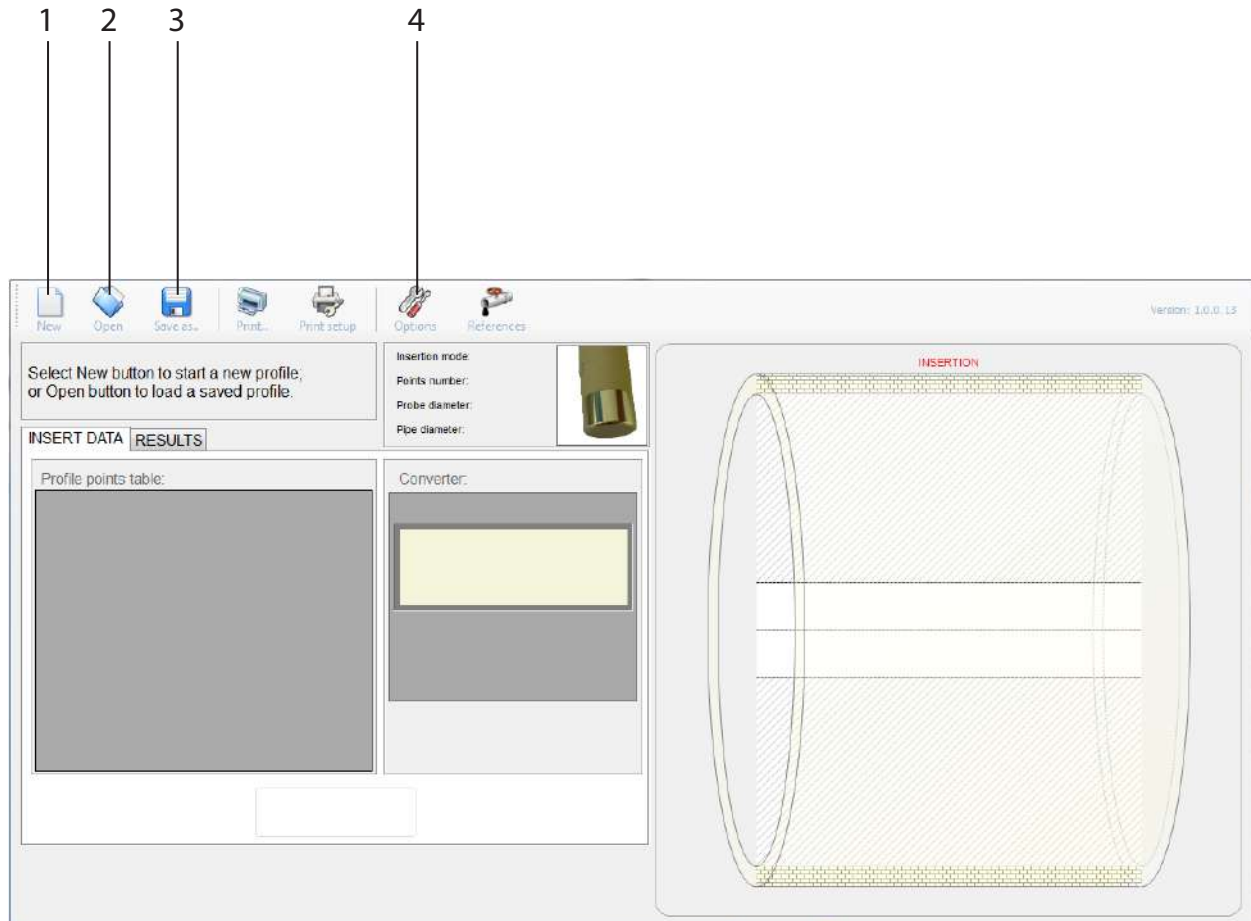

At program start-up appears the above window appears in addition to the normal print functions is possible:

- Load a profile previously saved by Profiler program from a text file (rif. 1)
- Open the form to insert a new profile (rif. 2)

PrimeProbe Flow Profiling Software - Options

Read measure: Automatically Manually

Protocol: ETP MCP LxCode

Converter protocol: HTP DDP

Communication: COM port: COM16

Converter: Show ETP console

Measure unit: m ft

Probe diameter: 23,0 mm

Graph options:

- Allow moving points graph
- View first and last segment
- View V mean lines
- View interpolation functions
- View first segment interpolation
- View V max Limit: 80 %

Graph colors:

Points: Lines:

Sheet (1): Sheet (2):

V mean: V values:

V max: Default

OK Cancel

By the button “Options” is possible to insert the basic parameters used in the calculations including:

- Diameter of the pipe in which the sensor probe is inserted
- Diameter of the sensor probe (this is usually 23 mm)
- Number of points in which the flow velocity is measured
- Type of point spacing that is correlated to the probe insertion depth at which measures are taken

Possible choices for the point spacing parameter are:

- Automatic: the point spacing will be automatically calculated by the program
- Manual: the insertion depth of every point will be inserted by the user.

For the program to operate correctly it is necessary to insert at least one point on the pipe axis and to insert the same number of points above and below the center line. The points must be inserted in the insertion depth order.

HOW TO ORDER

Code Example	Code/Description	
Suitable for piping diameter		
0	0	maximum insertion depth 150 mm
	1	maximum insertion depth 300 mm
	2	maximum insertion depth 500 mm
	3	maximum insertion depth 700 mm
	4	maximum insertion depth 1000 mm
	5	maximum insertion depth 2000 mm
	9	maximum insertion depth 80 mm
Sensor and electrodes material / lining		
A	A	Sensor material AISI316, head in PEEK, electrodes in Hastelloy C276, gasket in FKM
	B	Sensor material AISI316, head in PEEK, electrodes in AISI316, gasket in FKM
	Z	Sensor material: to be specified
Accessory for mounting in pressurised pipe line		
1	1	Mounting in pipe without pressure (installed using manual pressure); connection 1" UNI338 (GAS)
	2	Accessory kit, suitable for mounting in pressurised line, composed by: 1" hose-coupling (to weld on the pipe) and 1" ball valve (Bronze material); all connections 1" UNI 338 (GAS)
	3	Mounting in pipe without pressure (installed using manual pressure); connection 1" NPT
	4	Accessory kit, suitable for mounting in pressurised line, composed by: 1" hose-coupling (to weld on the pipe) and 1" ball valve (Bronze material); all connections 1" NPT
	6	Accessory kit, suitable for mounting in pressurised line, composed by: 1" hose-coupling (to weld on the pipe) and 1" ball valve (Bronze material); all connections 1" UNI 338 (GAS) + QUICK CONNECTIONS 1/8" for pressure sensor
	7	Accessory kit, suitable for mounting in pressurised line, composed by: 1" hose-coupling (to weld on the pipe) and 1" ball valve (Bronze material); all connections 1" NPT + QUICK CONNECTIONS 1/8" for pressure sensor
	8	Accessory kit, suitable for mounting in pressurised line, composed by: 1" UNI 338 (GAS) hose-coupling + QUICK CONNECTIONS 1/8" for pressure sensor
	9	Special connection: to be specified
	Suitable for Pipe Size	
A	A	> 150 mm
	B	< 150 mm
Number and electrodes material		
0	0	Standard ($V > 0,5 \text{ m/s} = 2\%$; $V < 0,5 \text{ m/s} = 1/V_{\text{measured}}$) ; V = fluid velocity
	1	Special
Number and electrodes material		
	A	Compact version , IP67 protection rate
	B	Separate version, Painted Aluminum JB, protection rate IP68, standing immersion with 1,5 m of head water - (DEFINE THE LENGHT - ADD THE COST)
	G	Separate version, Painted Aluminum JB, N° 1 connectors IP 68 suitable for fast cable connections - (DEFINE THE LENGHT - ADD THE COST)
	F	Separate version, Painted Aluminum JB, N° 2 connectors IP 68 suitable for fast cable connections - (DEFINE THE LENGHT - ADD THE COST)
	N	Separate version, Painted Aluminum JB , PREAMPLIFIER*, protection rate IP67 - (DEFINE THE LENGHT MAX 500 m-ADD THE COST)
	Q	Separate version, Painted Aluminum JB, PREAMPLIFIER*, N° 1 connectors IP 68 suitable for fast cable connection - (DEFINE THE LENGHT MAX 500 m-ADD THE COST)

A	U	Separate version, AISI 304 JB RAW, protection rate IP68, standing immersion with 1,5 m of head water - (DEFINE THE LENGHT - ADD THE COST)
	S	Separate version, AISI 304 JB RAW, with N° 1 connectors IP 68 suitable for fast cable connections - (DEFINE THE LENGHT - ADD THE COST)
	T	Separate version, AISI 304 JB RAW, N° 2 connectors IP 68 suitable for fast cable connections - (DEFINE THE LENGHT - ADD THE COST)
	P	Separate version, AISI 304 JB RAW, PREAMPLIFIER*, protection rate IP67 - (DEFINE THE LENGHT MAX 500 m-ADD THE COST)
	R	Separate version, AISI 304 JB RAW, PREAMPLIFIER* N° 1 connectors IP 68 suitable for fast cable connections to - (DEFINE THE LENGHT MAX 500 m-ADD THE COST)
	K	Separate version, AISI 304 JB POLISHED, protection rate IP68, standing immersion with 1,5 m of head water - (DEFINE THE LENGHT - ADD THE COST)
	Y	Separate version, AISI 304 JB POLISHED, with N° 1 connectors IP 68 suitable for fast cable connections - (DEFINE THE LENGHT - ADD THE COST)
	W	Separate version, AISI 304 JB POLISHED, N° 2 connectors IP 68 suitable for fast cable connections - (DEFINE THE LENGHT - ADD THE COST)
	V	Separate version, AISI 304 JB POLISHED, PREAMPLIFIER*, protection rate IP67 - (DEFINE THE LENGHT MAX 500 m-ADD THE COST)
	J	Separate version, AISI 304 JB POLISHED, PREAMPLIFIER* N° 1 connectors IP 68 suitable for fast cable connections to - (DEFINE THE LENGHT MAX 500 m-ADD THE COST)

Complete code
example for
order

MS3810-0A1A0A

ISOIL INDUSTRIA S.p.A.

HEAD OFFICE	SERVICE
Via Fratelli Gracchi, 27 20092 Cinisello Balsamo (MI) Tel +39 02 66027.1 Fax +39 02 6123202 sales@isoil.it	isomagservice@isoil.it

If you want to find the complete list of our distributors access at the following link:
<http://www.isoil.com/en>



Due to the constant technical development and improvement of its products, the manufacturer reserves the right to make changes and/or modify the information contained in this document without notice.