



ISOMAG

The friendly magmeter

DATA SHEET

MS 1000



CE



ISOIL 
INDUSTRIA

INDEX

TECHNICAL DATA	2
NOTES FOR PED DIRECTIVE FOR SENSOR	3
OVERALL DIMENSIONS	4
SENSOR VERSIONS/JUNCTION BOX	5
SEPARATE VERSION	6
INSTALLATION RECOMMENDATIONS	7
RECOMMENDED INSTALLATION PROCEDURE	8
SENSOR GROUNDING	9
PRESSURE LOSS CALCULATION (CONES 8° ANGLES)	10
HOW TO ORDER	11

TECHNICAL DATA

OVERALL FEATURES

Nominal diameter	<input type="checkbox"/> DN 25 ÷ 400
Minimum conductivity	<input type="checkbox"/> 5 mS/cm
Humidity Range	<input type="checkbox"/> 0÷100% (IP 67)
Accuracy	<input type="checkbox"/> See relevant converter data sheet
CE Certification	<input type="checkbox"/> Yes

STANDARD FEATURES

Body material	<input type="checkbox"/> Carbon steel painted
Nominal pressure	<input type="checkbox"/> 1600 kPa : all with PP and Ebonite lining <input type="checkbox"/> 4000 kPa : PTFE lining up to DN 150
Process connection	<input type="checkbox"/> Wafer Type
Version – protection rating	<input type="checkbox"/> Compact IP67
Body material	<input type="checkbox"/> Carbon Steel
Lining material	<input type="checkbox"/> Polypropylene (max PN 16) <input type="checkbox"/> Ebonite (DN 200 – 400) <input type="checkbox"/> PTFE (DN 25 – 150)
Gasket material (ONLY for lining in Polypropylene)	<input type="checkbox"/> FPM
Liquid temperature	<input type="checkbox"/> 0°C ÷ 60°C with PP lining <input type="checkbox"/> -5°C ÷ 80°C with ebonite lining <input type="checkbox"/> -20°C ÷ 100°C with PTFE lining in compact version
Vacuum resistance	<input type="checkbox"/> 20 Kpa (absolute) at 100 °C (60/80°C for PP/Ebonite)
Electrodes material	<input type="checkbox"/> Stainless steel AISI 316 <input type="checkbox"/> Hastelloy C <input type="checkbox"/> Platinum-rhodium <input type="checkbox"/> Titanium <input type="checkbox"/> Tantalum

OPTIONAL FEATURES

(CHECK FOR MORE DETAILS 'HOW TO ORDER' ON LAST PAGE)

Body material	<input type="checkbox"/> Stainless steel AISI 304 or 316
Gasket material (ONLY for lining in Polypropylene)	<input type="checkbox"/> EPDM
Liquid temperature	<input type="checkbox"/> -20°C ÷ 110°C with PTFE lining in separate version* * Contattare il costruttore per temperature più alte
Lining material	<input type="checkbox"/> On request
Electrodes material	<input type="checkbox"/> On request
Version – protection rating	<input type="checkbox"/> Separate version (max 20m) – IP 68 <input type="checkbox"/> Separate version (max 500 m), with preamplifier – IP 67 <input type="checkbox"/> Separate version (max 500 m), with preamplifier – IP 68

NOTES FOR PED DIRECTIVE FOR SENSOR

Here below the tables of products subject to Directive Pressure Equipment Device 2014/68/UE (PED) implemented by legislative decree February 15, 2016, n. 26

The tables show which category of PED is applicable according to the water operating temperature (TAB A T <110 ° C TAB B T > = 110 ° C), sensor's DN and its nominal pressure.

DN / PN CORRELATION TABLE AND PED DIRECTIVE

ONLY FOR FAMILY MS2500-MS1000 AND PN MAX 40 Bar

ONLY FOR METER WITH LINING IN PTFE

FOR METER FAMILY MS2500 TYPE FLANGE ONLY UNI EN1092 - P245GH OR ASTM A105

ONLY FOR METER FOR WATER WITH T. > 110°C

DN	PN - Nominal Pressure			
	B	C	D	E
25	USE PN 40		USE PN 40	40
32	USE PN 40			40
40	USE PN 40			40
50	USE PN 16	16		40
65		16		40
80		16		40
100		16		40
125		16		40
150		16		40
200	10	16		25
250	10	16	25	40
300	10	16	25	40
350	10	16	25	40
400	10	16	25	40
450	10	16	25	40
500	10	16	25	40

CONDITIONS TO SATISFY FOR T.> 110 ° C:

VAPOR PRESSURE p> 1.5 ATA

CAT I	
32>DN<=DN100+ PS*DN> 1000<=3500	
CAT II	
100>DN<=250 + PS*DN>3500<=5000	
CAT III	
DN> 250 + PS*DN>5000	

MEANING OF TABLES CODE

	= OUT OF PED
	= CAT. I
	= CAT. II
	= CAT. III
	= USE DIFF. PN

DN / PN CORRELATION TABLE AND PED DIRECTIVE

ONLY FOR METER FOR WATER WITH T.< 110°C

DN	PN - Nominal Pressure			
	B	C	D	E
25	USE PN 40		USE PN 40	40
32	USE PN 40			40
40	USE PN 40			40
50	USE PN 16			40
65				40
80				40
100				40
125				40
150				40
200	10			25
250	10	16	25	40
300	10	16	25	40
350	10	16	25	40
400	10	16	25	40
450	10	16	25	40
500	10	16	25	40
600	10	16	25	40
700	10	16	25	40
800	10	16	25	40
1000	10	16	25	40
1200	10	16	25	40
1300	10	16	25	40
1400	10	16	25	40
1500	10	16	25	40
1600	10	16	25	40
1700	10	16	25	40
1800	10	16	25	40
2000	10	16	25	40
2400	10	16	25	40

For products that falls in category I, is valid the declaration of conformity available on the following page; the products in Category II and III are supplied with a specific declaration of conformity for each instrument

OVERALL DIMENSIONS

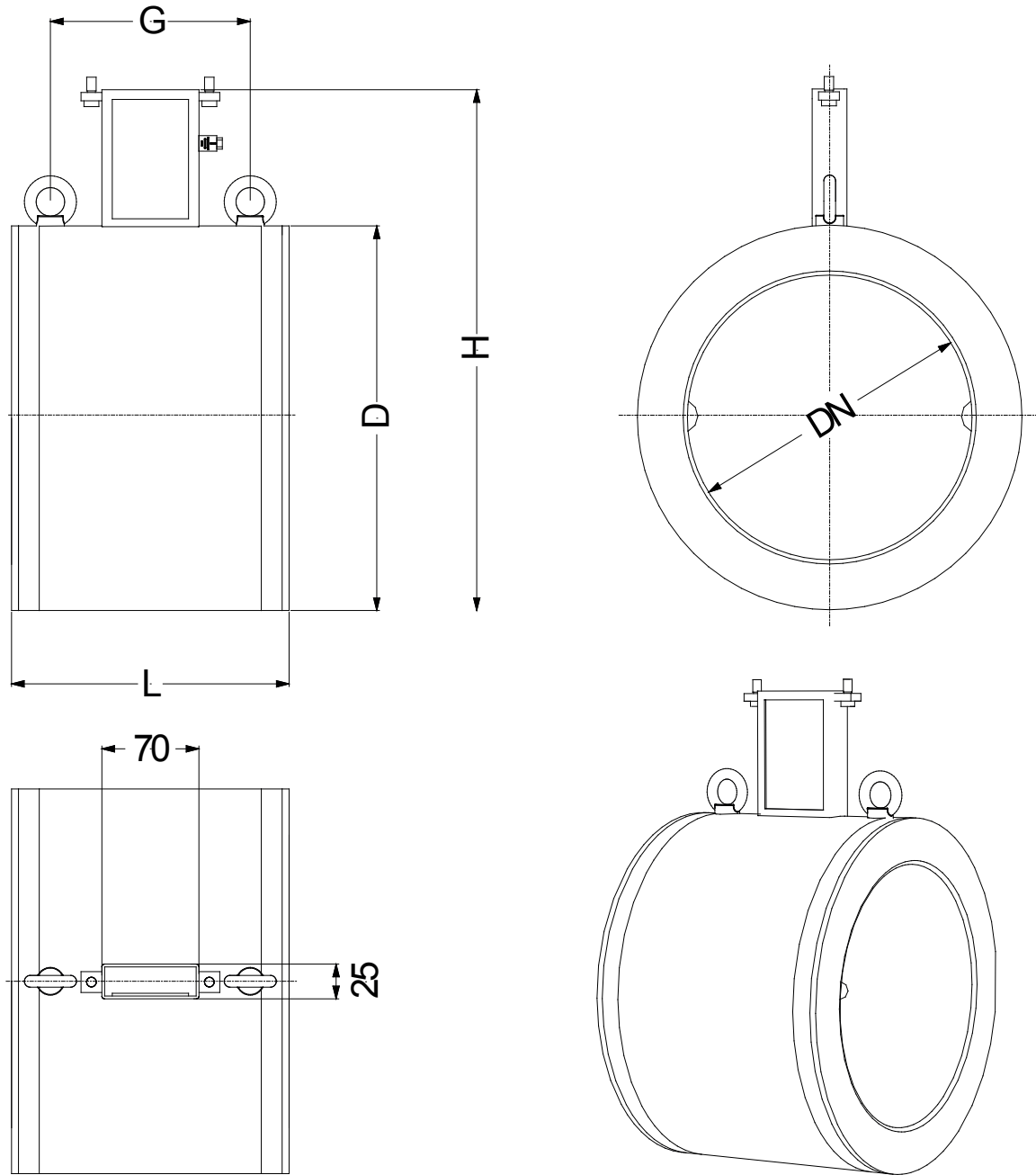

The manufacturer guarantees only English text available on our web site www.isoil.com

mm (inches)	DN													
	25 (1")	32 (1" 1/4)	40 (1" 1/2)	50 (2")	65 (2" 1/2)	80 (3")	100 (4")	125 (5")	150 (6")	200 (8")	250 (10")	300 (12")	350 (14")	400 (16")
L	+0	+0	+0	+0	+0	+0	+0	+0	+0	+0	+0	+0	+0	+0
	-3 (-0.12)	-3 (-0.12)	-3 (-0.12)	-3 (-0.12)	-3 (-0.12)	-3 (-0.12)	-3 (-0.12)	-3 (-0.12)	-3 (-0.12)	-3 (-0.12)	-5 (-0.20)	-5 (-0.20)	-5 (-0.20)	-5 (-0.20)
	100 (3.94)	100 (3.94)	100 (3.94)	100 (3.94)	150 (5.90)	150 (5.90)	150 (5.90)	180 (7.09)	180 (7.09)	200 (7.87)	250 (9.84)	300 (11.81)	350 (13.78)	400 (15.75)
H	147 (5.79)	153 (6.02)	161 (6.34)	177 (6.97)	199 (7.83)	209 (8.23)	239 (9.40)	263 (10.35)	291 (11.46)	362 (14.25)	417 (16.42)	467 (18.39)	527 (20.75)	579 (22.80)
D	62 (2.20)	67 (2.44)	78 (2.76)	92 (3.39)	108 (4.25)	118 (4.65)	148 (5.83)	172 (6.77)	200 (7.87)	271 (10.67)	326 (12.83)	376 (14.80)	436 (17.17)	488 (19.21)
G	-	-	-	-	-	-	-	-	-	144 (5.67)	194 (7.64)	244 (9.60)	294 (11.57)	344 (13.54)
Weight kg (lbs)	1.2 (2.64)	1.6 (3.52)	1.8 (3.96)	2 (4.4)	3.6 (7.92)	3.8 (8.36)	5 (11)	7.8 (17.16)	8.2 (18)	18.2 (40)	24 (53)	27 (59)	32 (70)	39 (86)
Flanges available	PTFE-EBANITE: PN10, PN16, PN25, PN40, ANSI150, ANSI,300 ANSI150							PP: PN10, PN16,			PTFE-EBANITE: PN10, PN16, ANSI150			

SENSOR VERSIONS/JUNCTION BOX

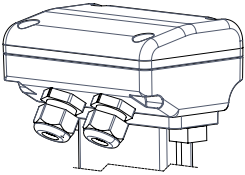
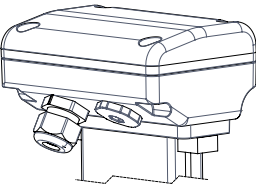
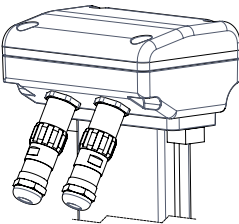
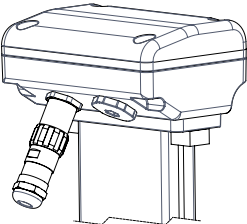
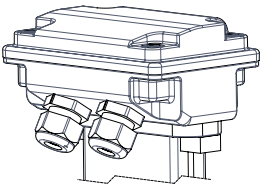
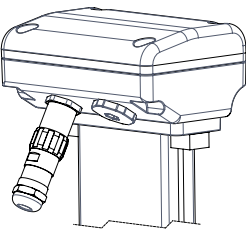
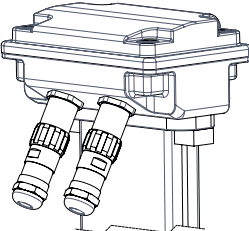
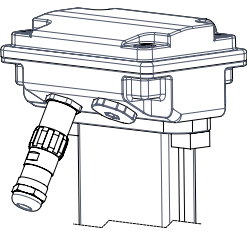
	1	2	3	4
A PAINTED ALUMINIUM				
B AISI 304				

PRICE LIST OPTIONS	JUNCTION BOX TYPE (surface finish)
A	Without junction box, converter connected on the connections box
B	A-1 A-2 only for ML110
G	A-4
F	A-3
N	A-2 with preamplifier
Q	A-4 with preamplifier
U	B-1 (raw) B-2 only for ML110 (raw)
S	B-4 (raw)
T	B-3 (raw)
P	B-2 with preamplifier (raw)
R	B-4 with preamplifier (raw)
K	B-1 (polished) B-2 only for ML110 (polished)
Y	B-4 (polished)
W	B-3 (polished)
V	B-2 with preamplifier (polished)
J	B-4 with preamplifier (polished)

SEPARATE VERSION

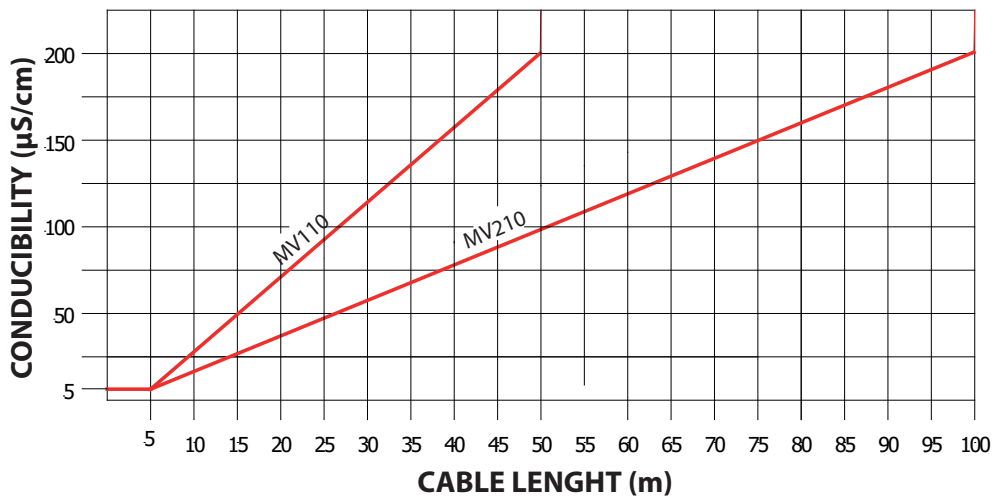
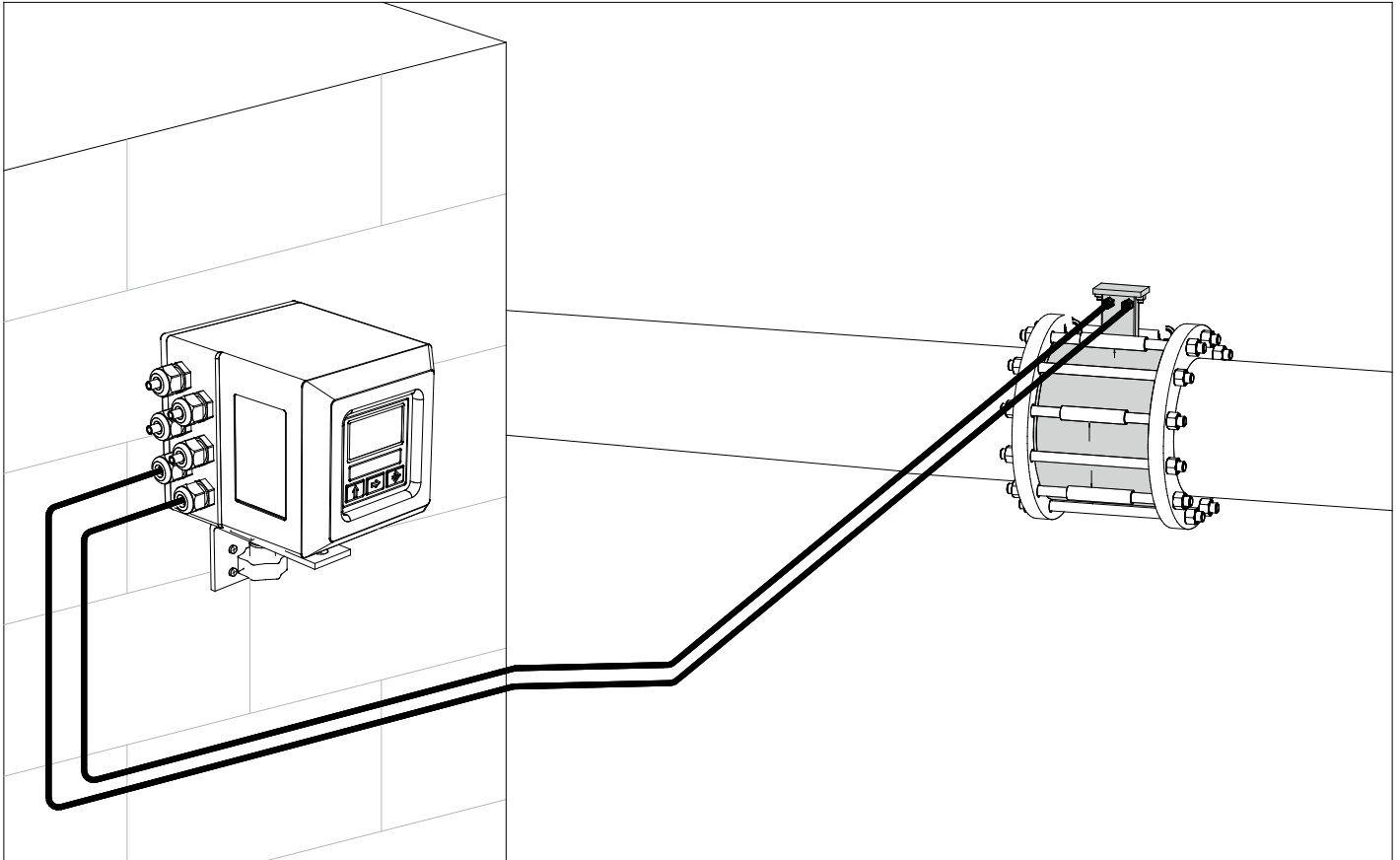

Notes:

- It is recommended to install the connection cables away from, or protect against sources of electromagnetic noise.
- The minimum conductivity of the liquid medium to ensure correct functionality of the empty pipe detection is 20 µS/cm

INSTALLATION RECOMMENDATIONS

In vertical installations an ascending flow is preferable. For vertical installations with descending flow direction contact the manufacturer

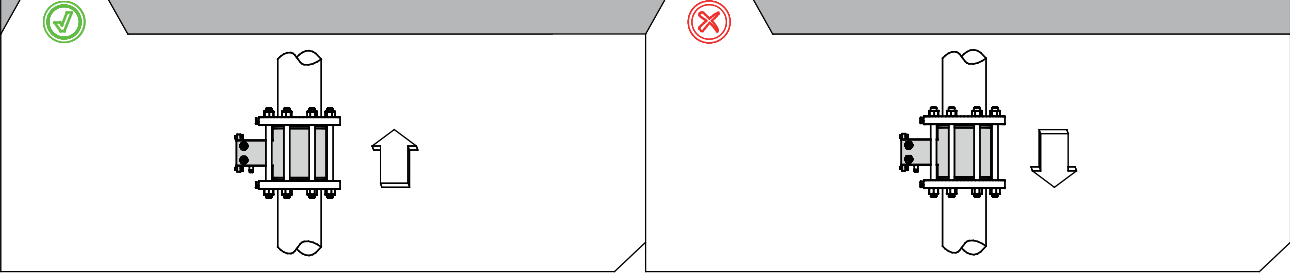

For installations in long pipe lines, please use anti vibration joints

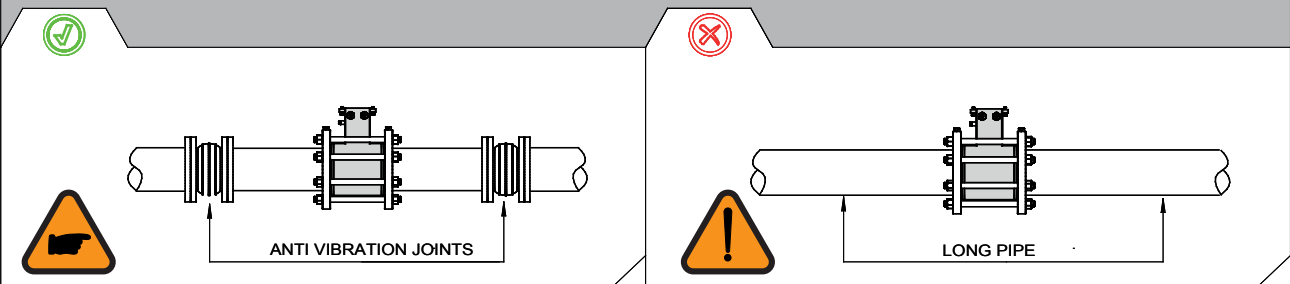

Avoid a partially empty pipe, during operation the pipe must be either completely full of liquid or completely empty

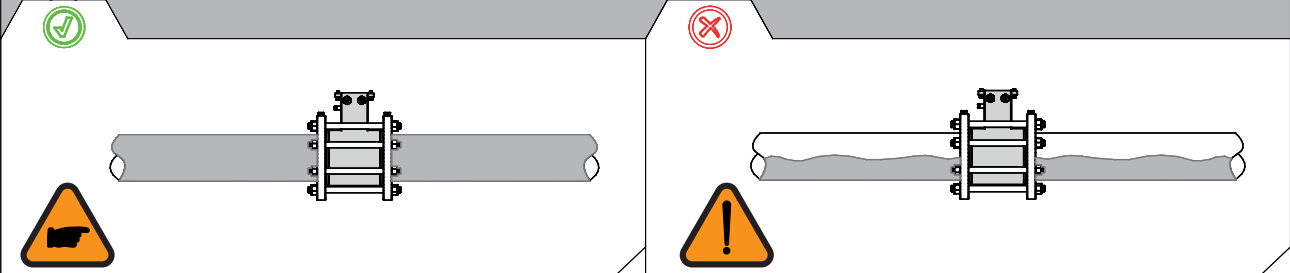

Install the sensor away from bends and hydraulic accessories

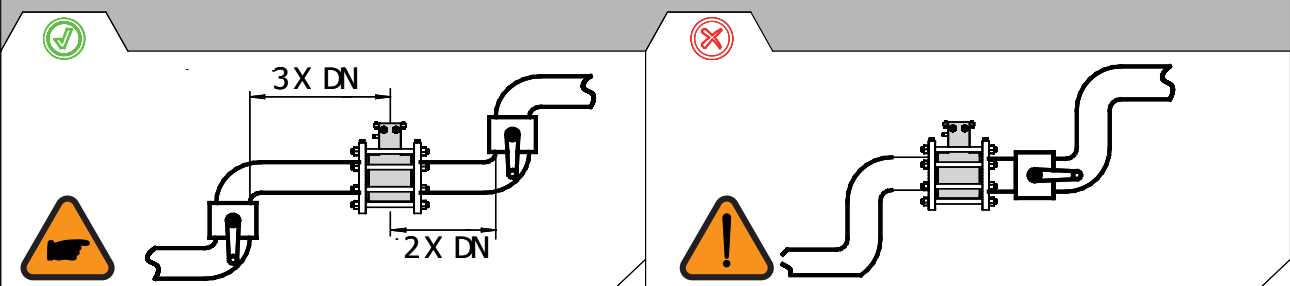

Avoid positioning flanges by tightening the nuts.

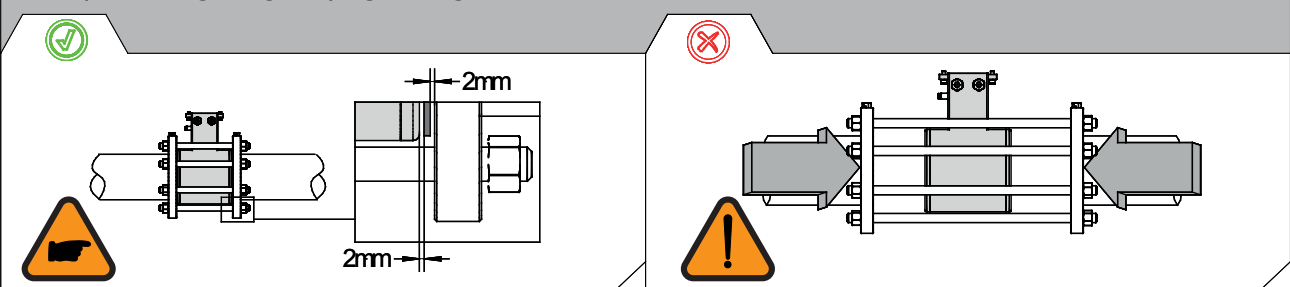

The manufacturer guarantees only English text available on our web site www.isomag.com

RECOMMENDED INSTALLATION PROCEDURE

Sensors weighing more than 20Kg are equipped of appropriate eyebolts to lift the sensor according to the drawing above.

The eyebolts support ONLY the weight of the meter.

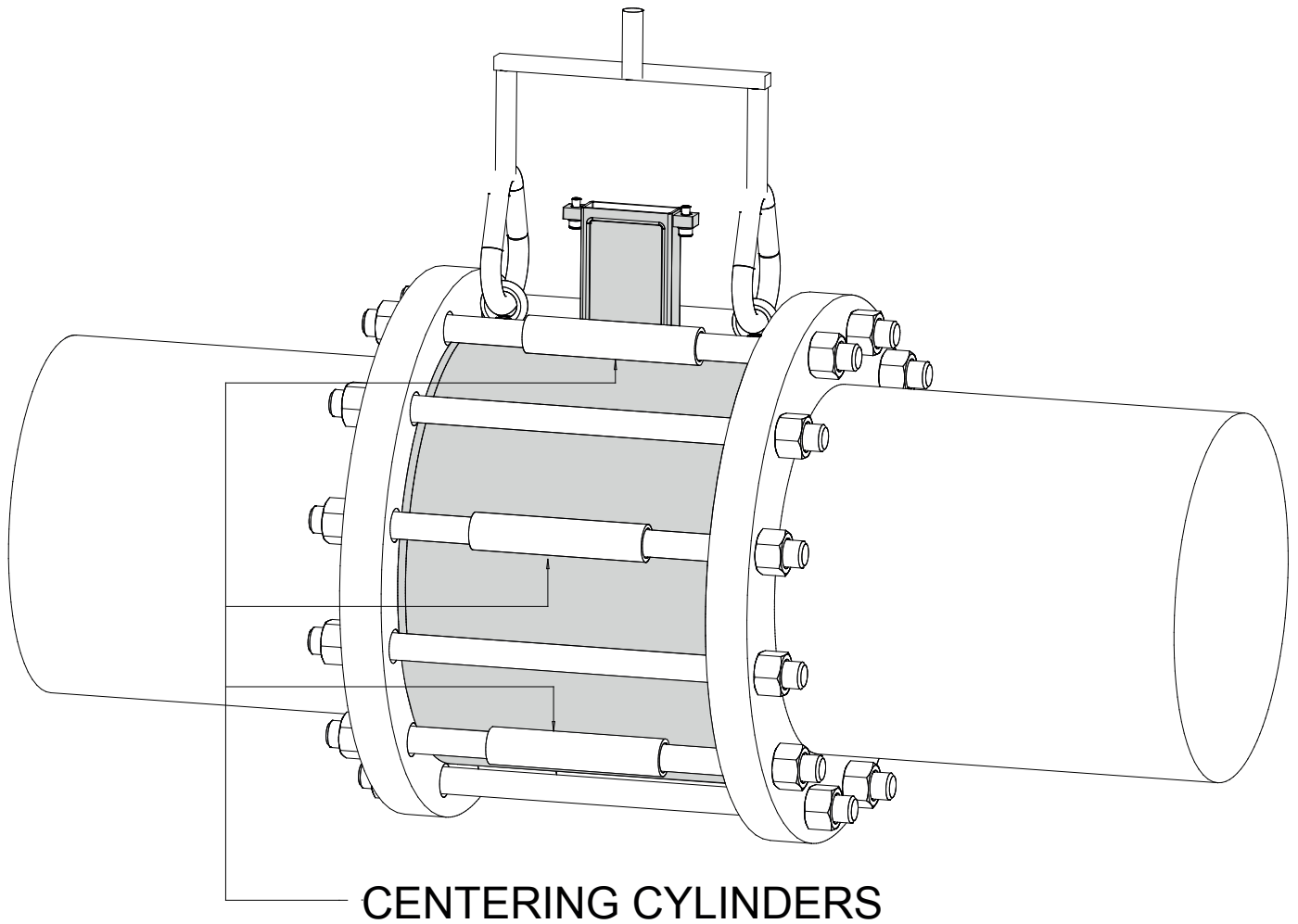

SENSOR GROUNDING

METALLIC PIPE

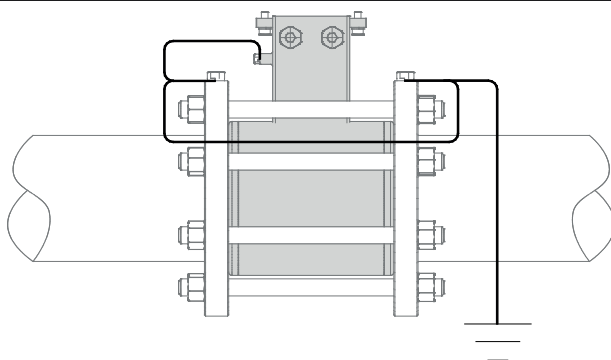

INSULATED PIPE

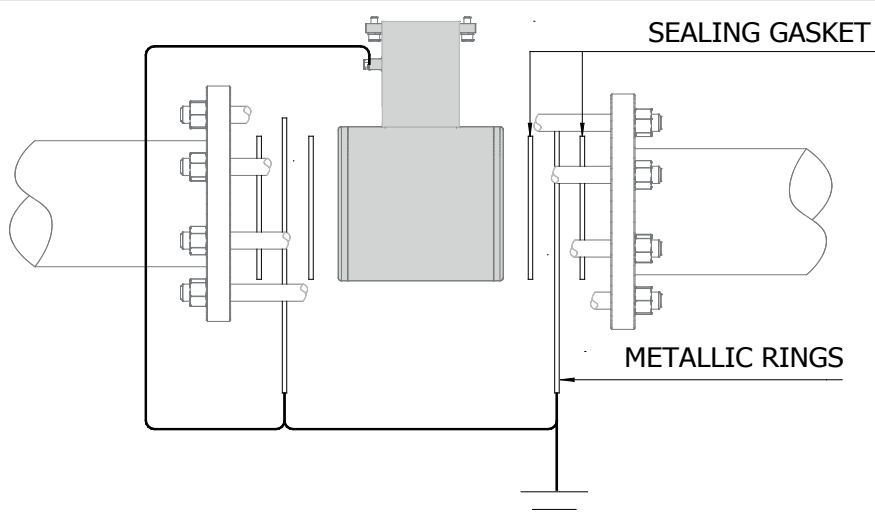

If the sensor has to be installed in a pipe made of an insulating material, the following are necessary:

- Inserting two metallic rings between the sensor flanges and the pipe line counter flanges
- or:
- Using a sensor with the additional grounding electrode

PIPE WITH CATHODIC PROTECTION

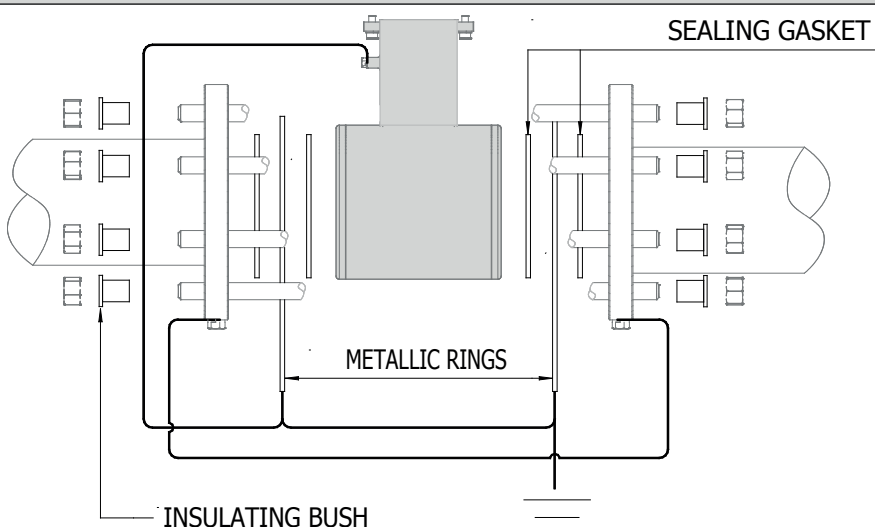

If the sensor has to be installed in the pipe with cathodic protection, the following are necessary:

- using insulating bushes to isolate the bolts
- Metallic grounding rings should be provided to ground the liquid using insulating gasket between the rings

The manufacturer guarantees only English text available on our web site www.isoil.com

PRESSURE LOSS CALCULATION (CONES 8° ANGLES)

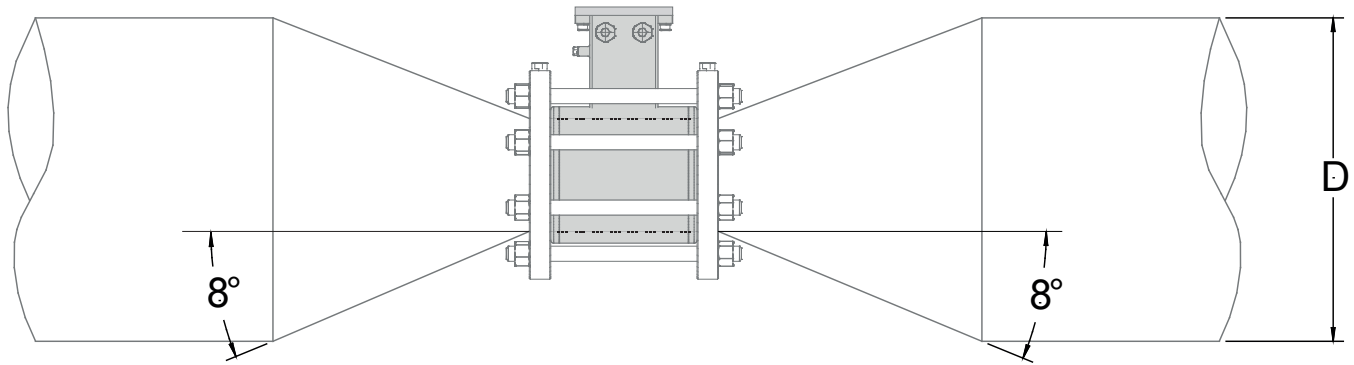

$$\Delta p = \left[0.10 + 0.20 \left(\left(\frac{d}{D} \right)^{-2} - 1 \right) \left(\frac{d}{D} \right)^4 \right] \left(\rho \frac{u^2}{2} \right)$$

Were:

- Dp = Pressure loss in [Pa]
- r = Fluid density [kg/m³] typical value r = 1000 [kg/m³]
- d = sensor diameter [m]
- D = pipe diameter (greater than sensor diameter) [m]
- u = Mean flow velocity in sensor diameter [m/s]

Calculation examples Δp [mbar]								
$d/D \backslash u$	1 [m/s]	2 [m/s]	3 [m/s]	4 [m/s]	5 [m/s]	6 [m/s]	7 [m/s]	8 [m/s]
0.5	1.1	4.3	9.6	17	26.6	38.3	52.1	68
0.6	0.9	3.6	8.2	14.6	22.7	32.7	44.6	58.2
0.7	0.8	3	6.8	12.2	19	27.4	37.2	48.6
0.8	0.6	2.5	5.7	10.1	15.7	22.7	30.9	40.3
0.9	0.5	2.1	4.8	8.6	13.4	19.3	26.3	34.3

Notes:

- $\rho = 1000$ [kg/m³] as goodness approximation of water density in common use.
- Inner diameter of sensor is used for d, express in meters.
- Indeed pressure loss equation is dimensionally correct in [Pa]. The equation results in table are show in [mbar].

HOW TO ORDER

CODE EXAMPLE		CODE/DESCRIPTION
Nominal Diameter / Lining / Liquid temperature / Measuring range		
T100	P25	DN25 (PN16), Polypropilene lining Measuring range 0...0,72/0...18 m3/h
	T25	DN25 (PN40), PTFE lining Measuring range 0...0,72/0...18 m3/h
	P32	DN32 (PN16), Polypropilene lining Measuring range 0...1,16/0...29 m3/h
	T32	DN32 (PN40), PTFE lining, Measuring range 0...1,16/0...29 m3/h
	P40	DN40 (PN16), Polypropilene lining, liquid maximum temperature 60 °C Measuring range 0...1,8/0...45 m3/h
	T40	DN40 (PN40), PTFE lining, liquid maximum temperature 150 °C Measuring range 0...1,8/0...45 m3/h
	P50	DN50 (PN16), Polypropilene lining, liquid maximum temperature 60 °C Measuring range 0...2,88/0...72 m3/h
	T50	DN50 (PN40), PTFE lining, liquid maximum temperature 150 °C Measuring range 0...2,88/0...72 m3/h
	P65	DN65 (PN16), Polypropilene lining, liquid maximum temperature 60 °C Measuring range 0...4,8/0...120 m3/h
	T65	DN65 (PN40), PTFE lining, liquid maximum temperature 150 °C Measuring range 0...4,8/0...120 m3/h
	P80	DN80 (PN16), Polypropilene lining, liquid maximum temperature 60 °C Measuring range 0...7,2/0...180 m3/h
	T80	DN80 (PN40), PTFE lining, liquid maximum temperature 150 °C Measuring range 0...7,2/0...180 m3/h
	P100	DN100 (PN16), Polypropilene lining, liquid maximum temperature 60 °C Measuring range 0...11,2/0...280 m3/h
	T100	DN100 (PN40), PTFE lining, liquid maximum temperature 150 °C Measuring range 0...11,2/0...280 m3/h
	P125	DN125 (PN16), Polypropilene lining, liquid maximum temperature 60 °C Measuring range 0...18/0...450 m3/h
	T125	DN125 (PN40), PTFE lining, liquid maximum temperature 150 °C Measuring range 0...18/0...450 m3/h
	P150	DN150 (PN16), Polypropilene lining, liquid maximum temperature 60 °C Measuring range 0...25,6/0...640 m3/h
	T150	DN150 (PN40), PTFE lining, liquid maximum temperature 150 °C Measuring range 0...25,6/0...640 m3/h
E200	DN200 (PN16), Ebanite lining, liquid maximum temperature 80 °C Measuring range 0...45,2/0...1130 m3/h	
E250	DN250 (PN16), Ebanite lining, liquid maximum temperature 80 °C Measuring range 0...70,8 / 0...1770 m3/h	
E300	DN300 (PN16), Ebanite lining, liquid maximum temperature 80 °C Measuring range 0...100,8 / 0...2520 m3/h	
E350	DN350 (PN16), Ebanite lining, liquid maximum temperature 80 °C Measuring range 0...138 / 0...3450 m3/h	
E400	DN400 (PN16), Ebanite lining, liquid maximum temperature 80 °C Measuring range 0...180 / 0...4500 m3/h	
Gasket material (internal tightness - only PP lining)		
0	0	No O-Ring (ONLY FOR PTFE/EBANITE LINING)
	1	O-Ring : FKM
	2	O-Ring : Epdm
	9	Gasket material: to be specified
Body material		
A	A	Body in Carbon Steel painted
	B	Body in Stainless Steel (AISI304)
	C	Body in Stainless Steel (AISI316)
	Z	Body material: other
Number and electrodes material		
2	2	n. 3 (2 measure + 1 for ground) electrodes in AISI316
	4	n. 3 (2 measure + 1 for ground) electrodes in Hastelloy C
	5	n. 3 (2 measure + 1 for ground) electrodes in Titanium
	6	n. 3 (2 measure + 1 for ground) electrodes in Tantalum; not available with Polypropilene/Rilsan
	7	n. 3 (2 measure + 1 for ground) electrodes in Platinum; not available with Polypropilene/Rilsan
	0	Electrode material: to be specified

Version / Protection rate

A	A	Compact version , IP67 protection rate
	B	Separate version, Painted Aluminum JB, protection rate IP68, standing immersion with 1,5 m of head water - (DEFINE THE CABLE LENGHT - ADD THE COST)
	G	Separate version, Painted Aluminum JB, N° 1 connectors IP 68 suitable for fast cable connections - (DEFINE THE CABLE LENGHT - ADD THE COST)
	F	Separate version, Painted Aluminum JB, N° 2 connectors IP 68 suitable for fast cable connections - (DEFINE THE CABLE LENGHT - ADD THE COST)
	N	Separate version, Painted Aluminum JB , PREAMPLIFIRE*, protection rate IP67 - (DEFINE THE CABLE LENGHT MAX 500 m-ADD THE COST)
	Q	Separate version, Painted Aluminum JB, PREAMPLIFIRE*, N° 1 connectors IP 68 suitable for fast cable connection - (DEFINE THE CABLE LENGHT MAX 500 m-ADD THE COST)
	U	Separate version, AISI 304 JB RAW, protection rate IP68, standing immersion with 1,5 m of head water - (DEFINE THE CABLE LENGHT - ADD THE COST)
	S	Separate version, AISI 304 JB RAW, with N° 1 connectors IP 68 suitable for fast cable connections - (DEFINE THE CABLE LENGHT - ADD THE COST)
	T	Separate version, AISI 304 JB RAW, N° 2 connectors IP 68 suitable for fast cable connections - (DEFINE THE CABLE LENGHT - ADD THE COST)
	P	Separate version, AISI 304 JB RAW, PREAMPLIFIRE*, protection rate IP67 - (DEFINE THE CABLE LENGHT MAX 500 m-ADD THE COST)
	R	Separate version, AISI 304 JB RAW, PREAMPLIFIRE* N° 1 connectors IP 68 suitable for fast cable connections to - (DEFINE THE CABLE LENGHT MAX 500 m-ADD THE COST)
	K	Separate version, AISI 304 JB POLISCHED, protection rate IP68, standing immersion with 1,5 m of head water - (DEFINE THE CABLE LENGHT - ADD THE COST)
	Y	Separate version, AISI 304 JB POLISCHED, with N° 1 connectors IP 68 suitable for fast cable connections - (DEFINE THE CABLE LENGHT - ADD THE COST)
	W	Separate version, AISI 304 JB POLISCHED, N° 2 connectors IP 68 suitable for fast cable connections - (DEFINE THE CABLE LENGHT - ADD THE COST)
	V	Separate version, AISI 304 JB POLISCHED, PREAMPLIFIRE*, protection rate IP67 - (DEFINE THE CABLE LENGHT MAX 500 m-ADD THE COST)
J	Separate version, AISI 304 JB POLISCHED, PREAMPLIFIRE* N° 1 connectors IP 68 suitable for fast cable connections to - (DEFINE THE CABLE LENGHT MAX 500 m-ADD THE COST)	



Complete code
example for
order



MS1000-T100-0A2A

The manufacturer guarantees only English text available on our web site www.isoil.com

ISOIL INDUSTRIA S.p.A.

HEAD OFFICE	SERVICE
Via Fratelli Gracchi, 27 20092 Cinisello Balsamo (MI) Tel +39 02 66027.1 Fax +39 02 6123202 sales@isoil.it	<small>isomagservice@isoil.it</small>

If you want to find the complete list of our distributors access at the following link:
<http://www.isoil.it/en>



Due to the constant technical development and improvement of its products, the manufacturer reserves the right to make changes and/or modify the information contained in this document without notice.