

# ISOMAG

*The friendly magmeter*

## DATA SHEET



**MS5000**

**CE**

**ISOIL**   
INDUSTRIA



# INDEX

TECHNICAL DATA	2
OVERALL DIMENSIONS	3
INSTALLATION	4
INSTALLATION RECOMMENDATION	5
SEPARATE VERSION	6
PRESSURE LOSS CALCULATION (CONES 8° ANGLES)	7
HOW TO ORDER	8



The manufacturer guarantees only English text available on our web site [www.isoli.com](http://www.isoli.com)

**TECHNICAL DATA****OVERALL FEATURES**

Nominal diameter	<input type="checkbox"/> DN 25 – 50 – 80
Minimum conductivity	<input type="checkbox"/> 5 $\mu$ S/cm
Humidity Range	<input type="checkbox"/> 0÷100% (IP 67)
Accuracy	<input type="checkbox"/> See relevant converter data sheet
CE Certification	<input type="checkbox"/> Yes

**STANDARD FEATURES**

Body material	<input type="checkbox"/> Polyurethane rubber
Nominal pressure	<input type="checkbox"/> 600 kPa
Process connection	<input type="checkbox"/> Wrapper fixing
Version – protection rating	<input type="checkbox"/> Compact IP67
Lining material	<input type="checkbox"/> Polyurethane rubber
Gasket material	<input type="checkbox"/> FPM
Liquid temperature	<input type="checkbox"/> 0°C ÷ 50°C
Vacuum resistance	<input type="checkbox"/> 20 Kpa a 50 °C
Electrodes material	<input type="checkbox"/> SS AISI 316L <input type="checkbox"/> Hastelloy C <input type="checkbox"/> Titanium

**OPTIONAL FEATURES***(CHECK FOR MORE DETAILS 'HOW TO ORDER' ON LAST PAGE)*

Gasket material	<input type="checkbox"/> EPDM
Version – protection rating	<input type="checkbox"/> Separate (max 20m) – IP 68

OVERALL DIMENSIONS

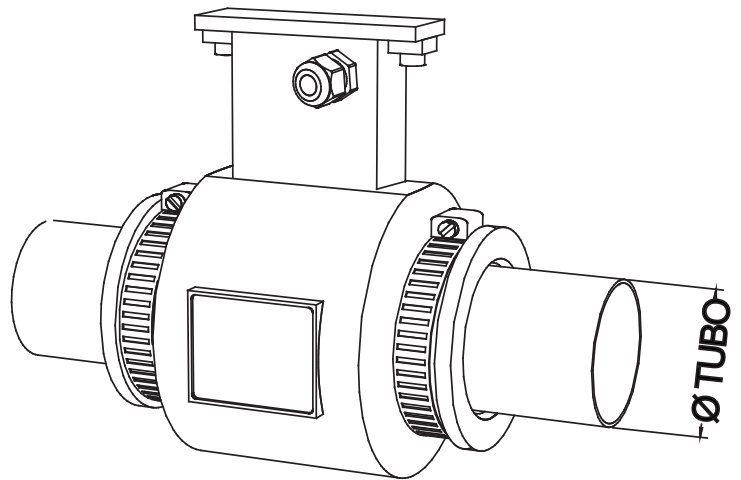
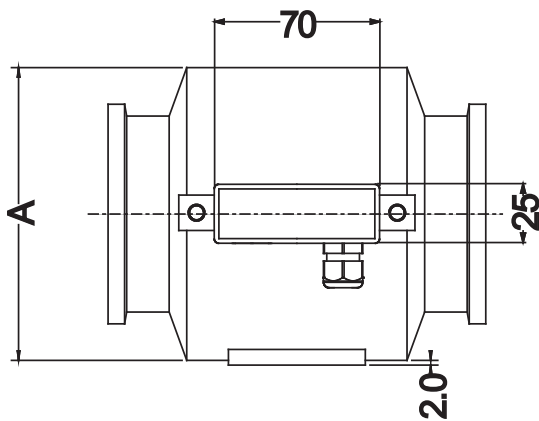
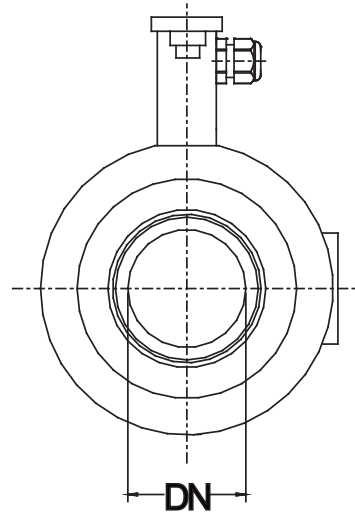
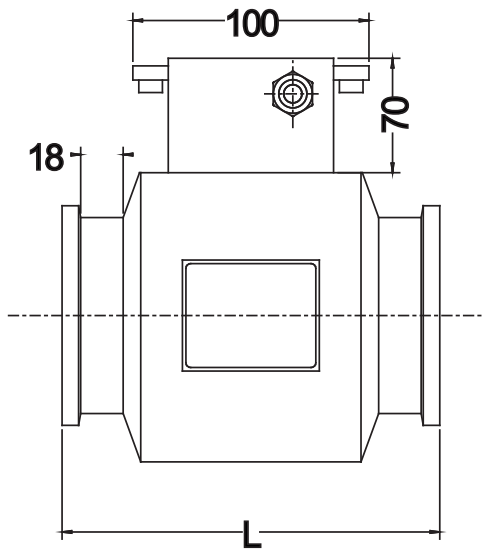

DIMENSIONS mm	DN		
	25 (1")	50 (2")	80 (3")
A	80	124	154
L	135	160	190
Ø PIPE (ISO SERIES)	33.7	60.3	88.9

The manufacturer guarantees only English text available on our web site www.isoli.com

# INSTALLATION

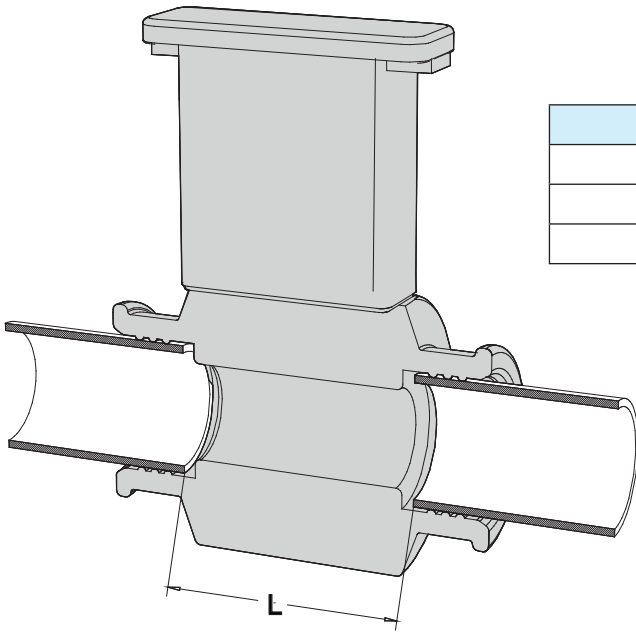

DN	L (mm)	L (inches)
25	92	3.62
50	108	4.25
80	138	5.43

The manufacturer guarantees only English text available on our web site www.isoil.com

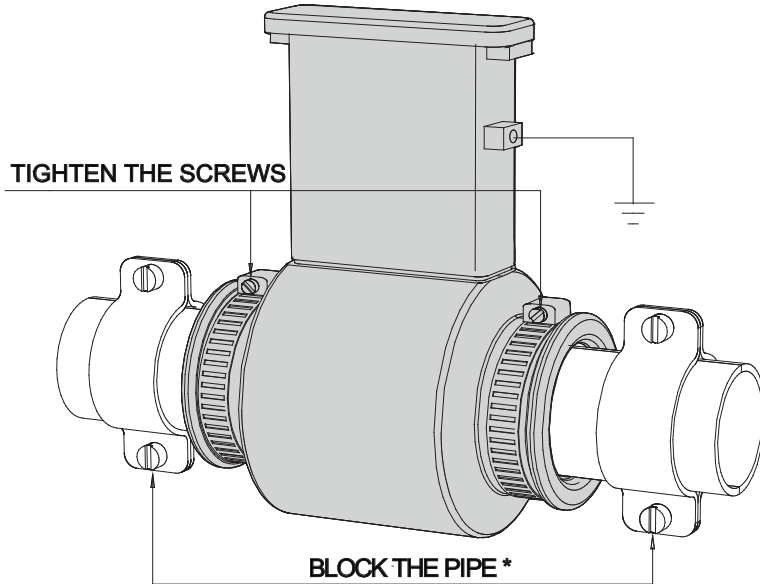

\* Lock the pipe to a fixed support

- Verify the flow direction
- Assemble the sensor to the pipe
- Tighten the wrapper to avoid possible leakages
- Connect the instrument to ground by the screw attachment on sensor

# INSTALLATION RECOMMENDATION

In vertical installations an ascending flow is preferable. For vertical installations with descending flow direction contact the manufacturer

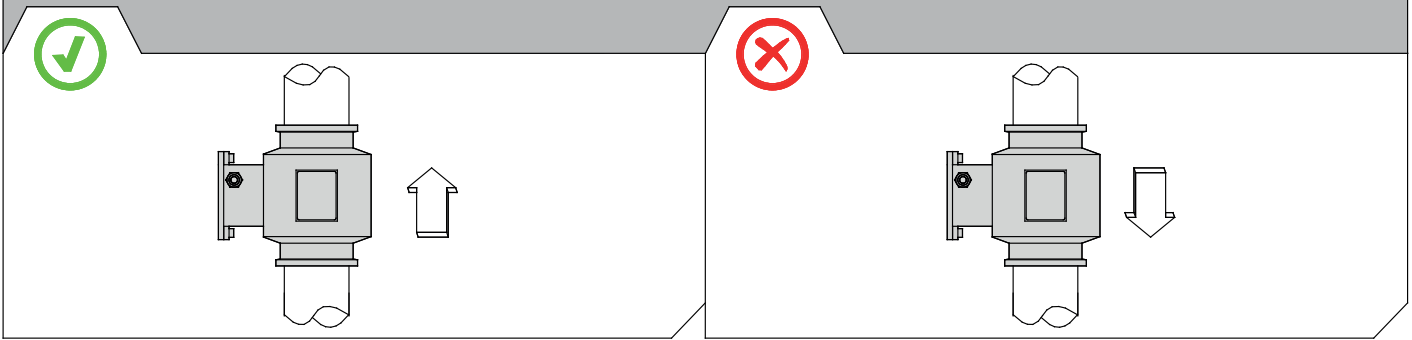

For installations in long pipe lines, please use anti vibration joints

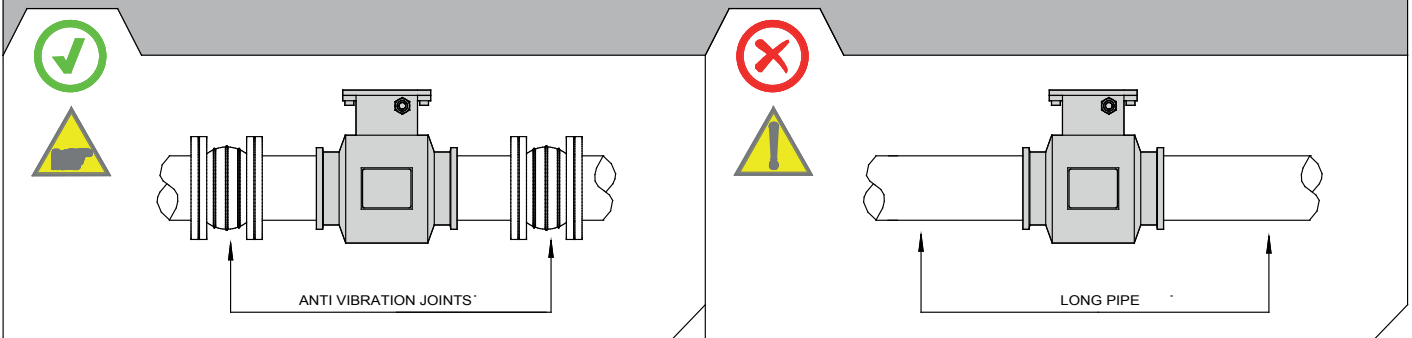

Avoid a partially empty pipe, during operation the pipe must be either completely full of liquid or completely empty

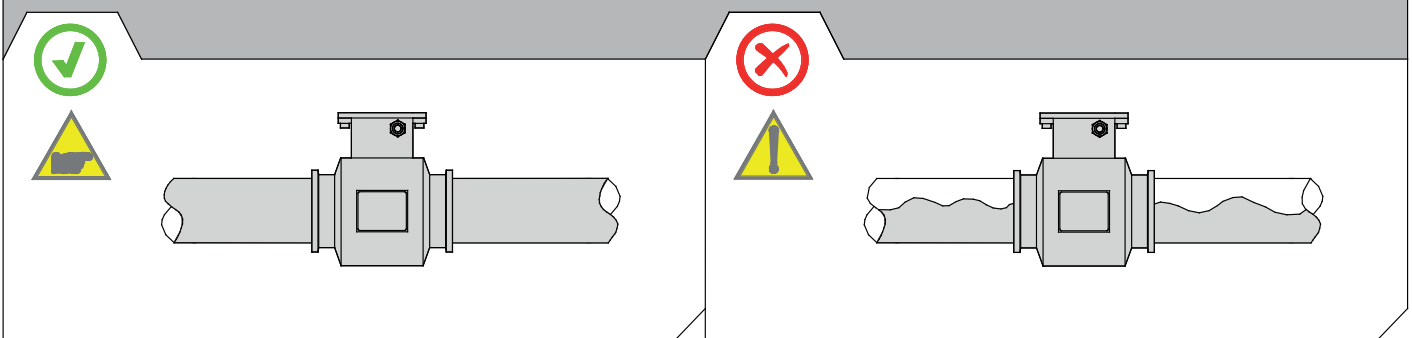

Install the sensor away from bends and hydraulic accessories

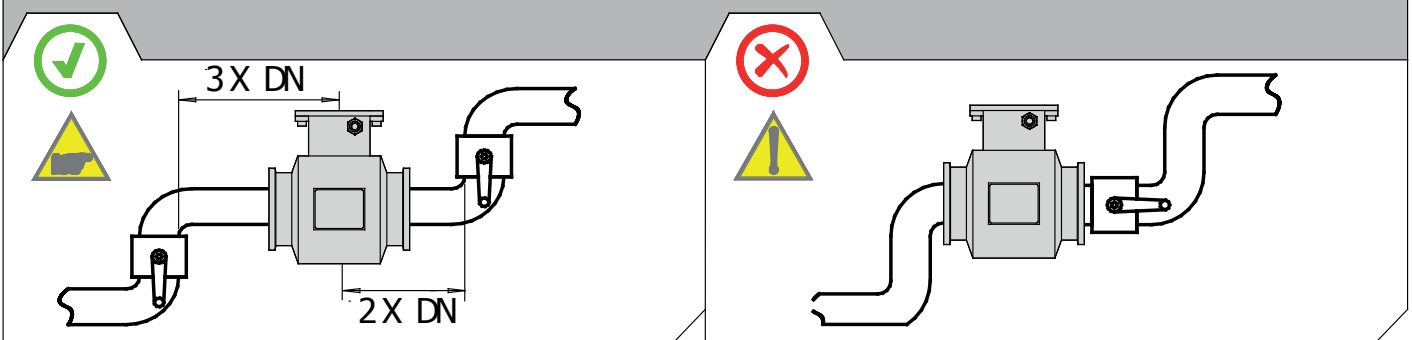

The manufacturer guarantees only English text available on our web site [www.isomag.com](http://www.isomag.com)



SEPARATE VERSION

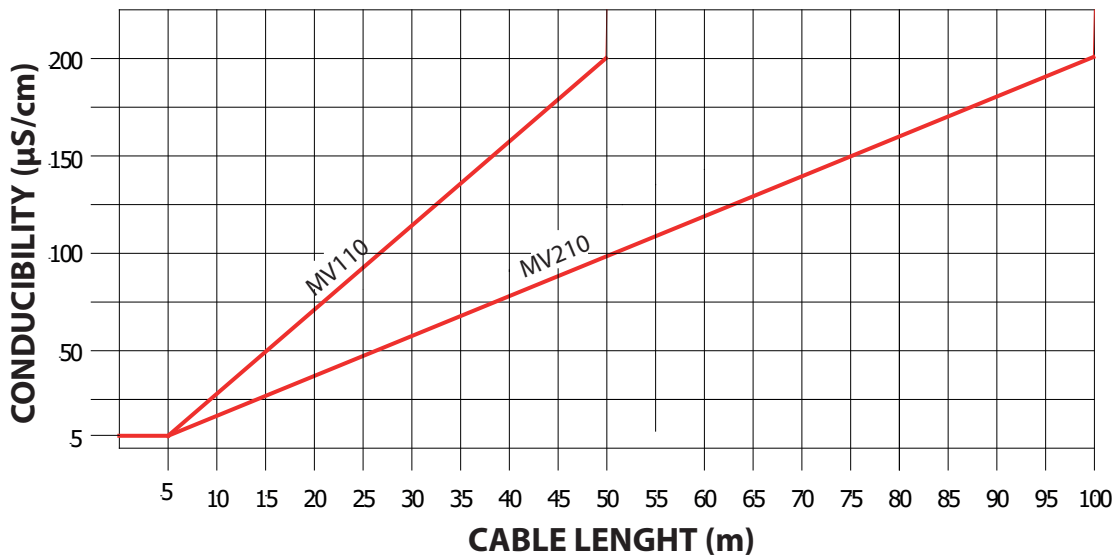
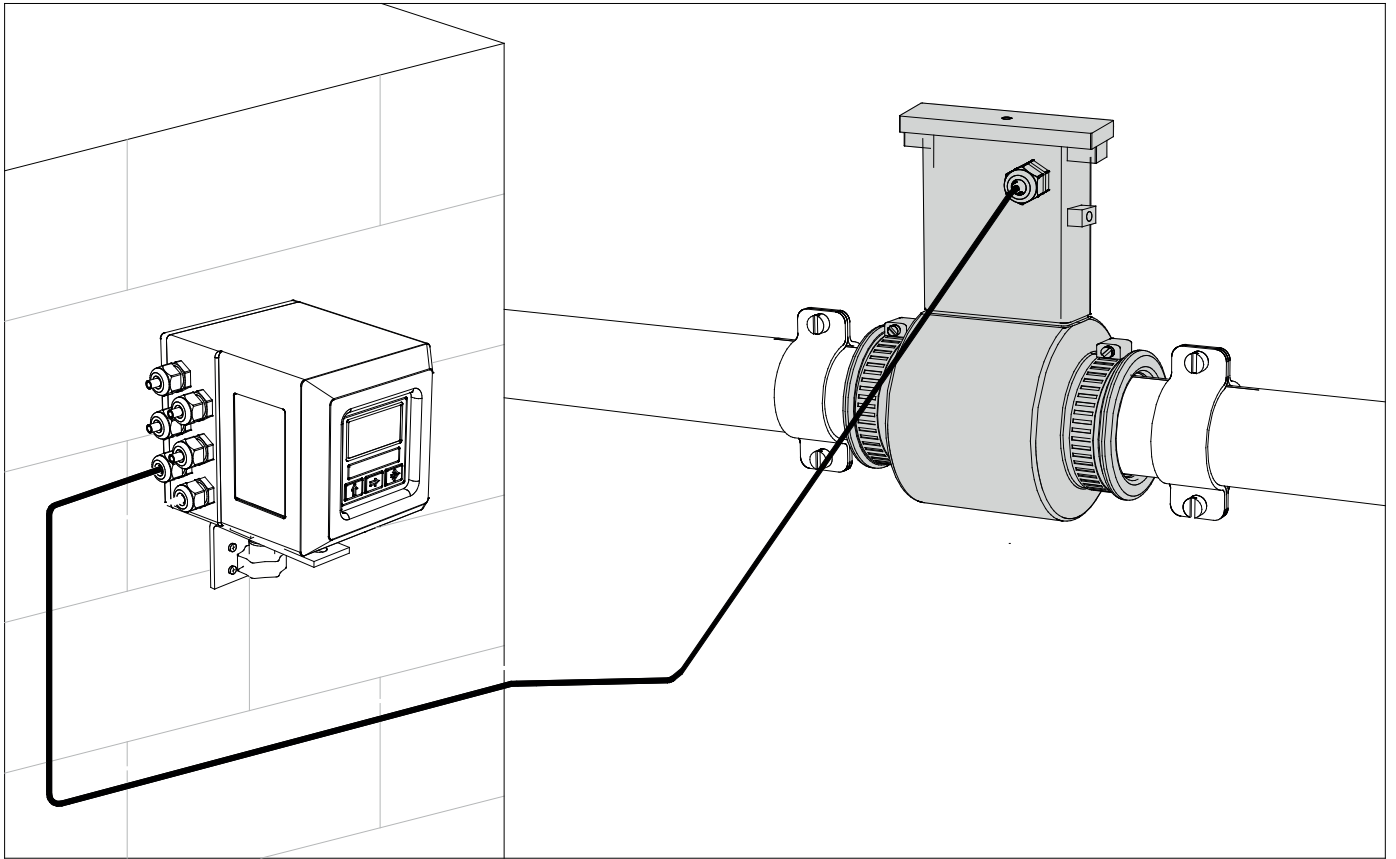

Note:

- It is recommended to install the connection cables away from, or protect against sources of electromagnetic noise.
- The minimum conductivity of the liquid medium to ensure correct functionality of the empty pipe detection is 20 µS/cm

## PRESSURE LOSS CALCULATION (CONES 8° ANGLES)

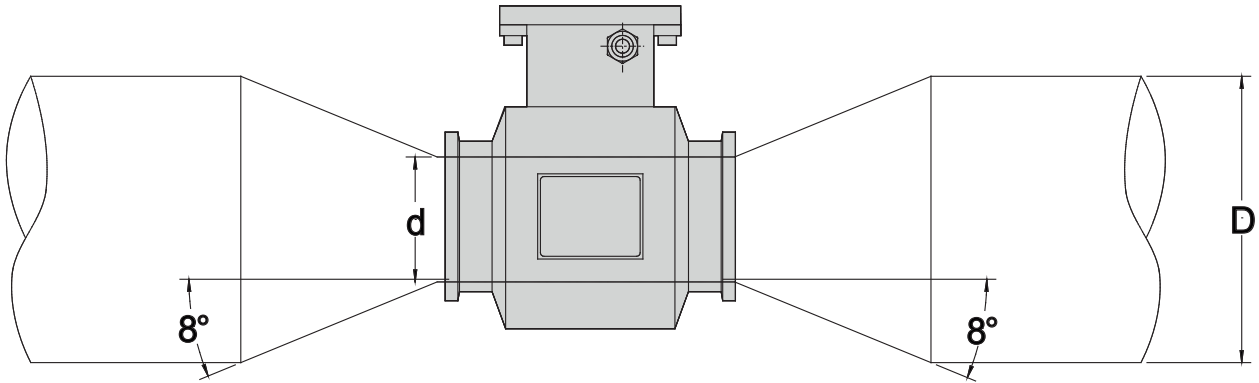

$$\Delta p = \left[ 0.10 + 0.20 \left( \left( \frac{d}{D} \right)^{-2} - 1 \right)^2 \left( \frac{d}{D} \right)^4 \right] \left( \rho \frac{u^2}{2} \right)$$

### Were:

- Dp = Pressure loss in [Pa]  
 r = Fluid density [kg/m<sup>3</sup>] typical value r = 1000 [kg/m<sup>3</sup>]  
 d = sensor diameter [m]  
 D = pipe diameter (greater than sensor diameter) [m]  
 u = Mean flow velocity in sensor diameter [m/s]

Calculation examples $\Delta p$ [mbar]								
$d/D$ \ u	1 [m/s]	2 [m/s]	3 [m/s]	4 [m/s]	5 [m/s]	6 [m/s]	7 [m/s]	8 [m/s]
<b>0.5</b>	1.1	4.3	9.6	17	26.6	38.3	52.1	68
<b>0.6</b>	0.9	3.6	8.2	14.6	22.7	32.7	44.6	58.2
<b>0.7</b>	0.8	3	6.8	12.2	19	27.4	37.2	48.6
<b>0.8</b>	0.6	2.5	5.7	10.1	15.7	22.7	30.9	40.3
<b>0.9</b>	0.5	2.1	4.8	8.6	13.4	19.3	26.3	34.3

### Notes:

- r = 1000 [kg/m<sup>3</sup>] as goodness approximation of water density in common use.
- Inner diameter of sensor is used for d, express in meters.
- Indeed pressure loss equation is dimensionally correct in [Pa]. The equation results in table are show in [mbar].

## HOW TO ORDER

CODE EXAMPLE		CODE/DESCRIPTION
<b>Nominal Diameter / Lining / Liquid temperature / Measuring range</b>		
<b>C25</b>	C25	DN25 (1") , Polyurethane lining, liquid maximum temperature 50 °C measuring range 0...0,72/0...18 m3/h
	C50	DN50 (2"), Polyurethane lining, liquid maximum temperature 50 °C measuring range 0...2,88/0...72 m3/h
	C80	DN80 (3"), Polyurethane lining, liquid maximum temperature 50 °C measuring range 0...7,2/0...180 m3/h
<b>Gasket material ( internal tightness - only PP lining)</b>		
A	A	Without gasket
<b>Body material</b>		
2	2	n. 3 measure electrodes in AISI316
	4	n. 3 (2 measure + 1 for ground) electrodes in Hastelloy C
	5	n. 3 (2 measure + 1 for ground) electrodes in Titanium
<b>Version/ protection rate</b>		
A	A	Compact execution, IP67 protection rate, liquid maximum temperature 50 °C
	B	Separate execution , maximum length 20m, remember to added the cables cost, protection rate IP68 (standing immersion with 1,5 m of head water)



Example of Complete code for order



MS5000-C25-A2A

The manufacturer guarantees only English text available on our web site www.isoil.com

## ISOIL INDUSTRIA S.p.A.

HEAD OFFICE	SERVICE
Via Fratelli Gracchi, 27 20092 Cinisello Balsamo (MI) Tel +39 02 66027.1 Fax +39 02 6123202 sales@isoil.it	isomagservice@isoil.it

If you want to find the complete list of our distributors access at the following link:  
<http://www.isoil.it/en>



Due to the constant technical development and improvement of its products, the manufacturer reserves the right to make changes and/or modify the information contained in this document without notice.